

# Trainee document MX-13 engine EN2/10

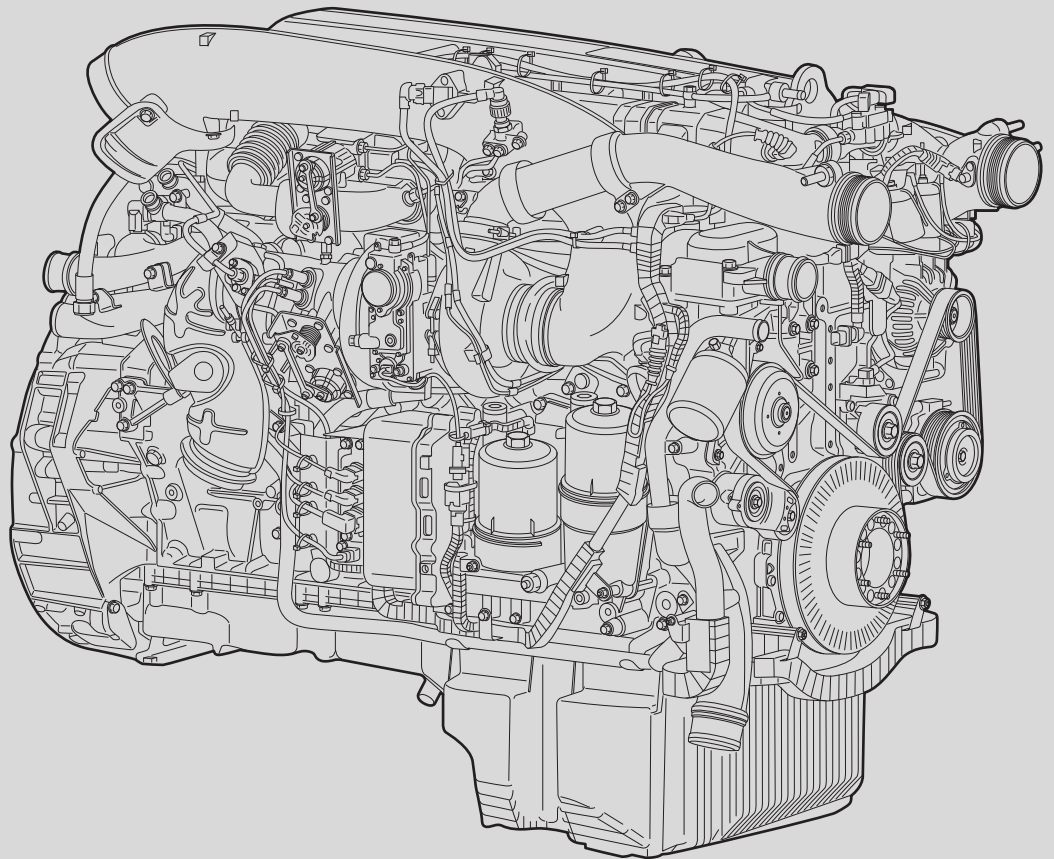



©201243 DAF Trucks N.V., Eindhoven,  
The Netherlands.

In the interest of continuing product development,  
DAF reserves the right to change specifications  
or products at any time without prior notice.

No part of this publication may be reproduced  
and/or published by printing, by photocopying, on  
microfilm or in any way whatsoever without the  
prior consent in writing of DAF Trucks N.V.

The content of this training material is solely  
meant for training purposes and can therefore not  
be used for actual "life" situations. The  
information in this document is subject to  
changes. For the correct chassis specific  
technical data it is imperative to consult the  
service documentation via Service Rapido.





## **STRUCTURE**

---

**BASIC ENGINE**

**1**

**FUEL SYSTEM**

**2**

**AIR INLET AND EXHAUST**

**3**

**COOLING SYSTEM**

**4**

**LUBRICATION SYSTEM**

**5**



**CONTENTS**

	<b>Page</b>	<b>Date</b>
<b>1. INTRODUCTION</b> .....	1-1 .....	201243
1.1 General Information MX-13 engine .....	1-1 .....	201243
<b>2. COMPONENTS</b> .....	2-1 .....	201243
2.1 Electronic control unit PCI .....	2-1 .....	201243
2.2 Cylinder head and valve cover .....	2-2 .....	201243
2.3 Pistons and liners .....	2-3 .....	201243
2.4 Crankshaft and bearings .....	2-5 .....	201243
2.5 Camshaft .....	2-7 .....	201243
2.6 Gear train .....	2-9 .....	201243
2.7 Oil sump .....	2-10 .....	201243
2.8 Crankcase ventilation module (L090) .....	2-13 .....	201243



# **BASIC ENGINE**

---

## Contents

**1**

# 1. INTRODUCTION

## 1.1 GENERAL INFORMATION MX-13 ENGINE

The MX-13 engine is compliant with Euro 6- emission regulations. The MX-13 engine has the following technical layout:

- 6-cylinder in line
- 4 valves per cylinder
- Common Rail Diesel Direct Injection
- Exhaust Gas Recirculation (EGR)
- PCI engine control system (PACCAR Common Rail Injection)
- EAS-3 (Emission Aftertreatment System)
- VTG (Variable Turbo Geometry) with intercooling
- Bore & stroke 130 x 162 mm
- Displacement 12.9 ltr.
- Compression ratio 17.7:1
- Weight approximately 1260 kg.

Figures may be dependent of vehicle configuration.

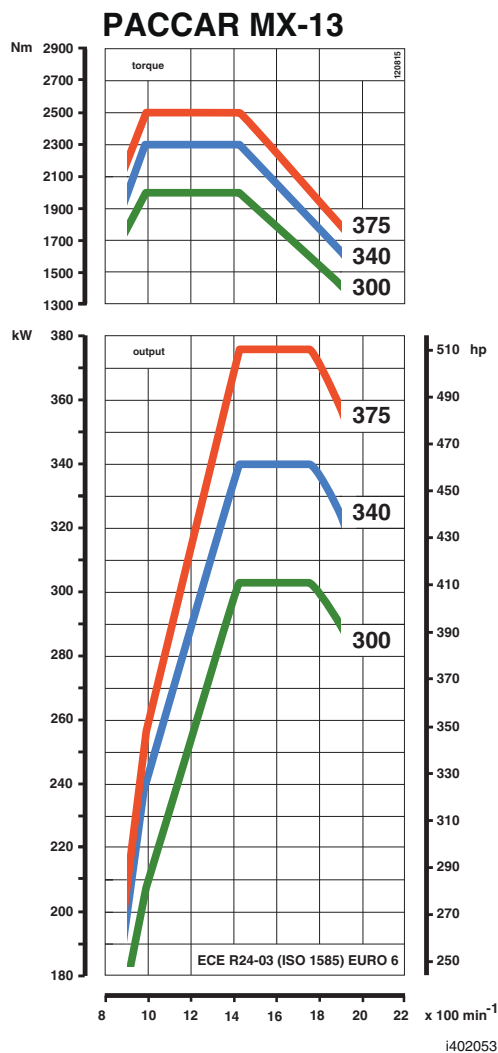

# BASIC ENGINE

## Introduction

1

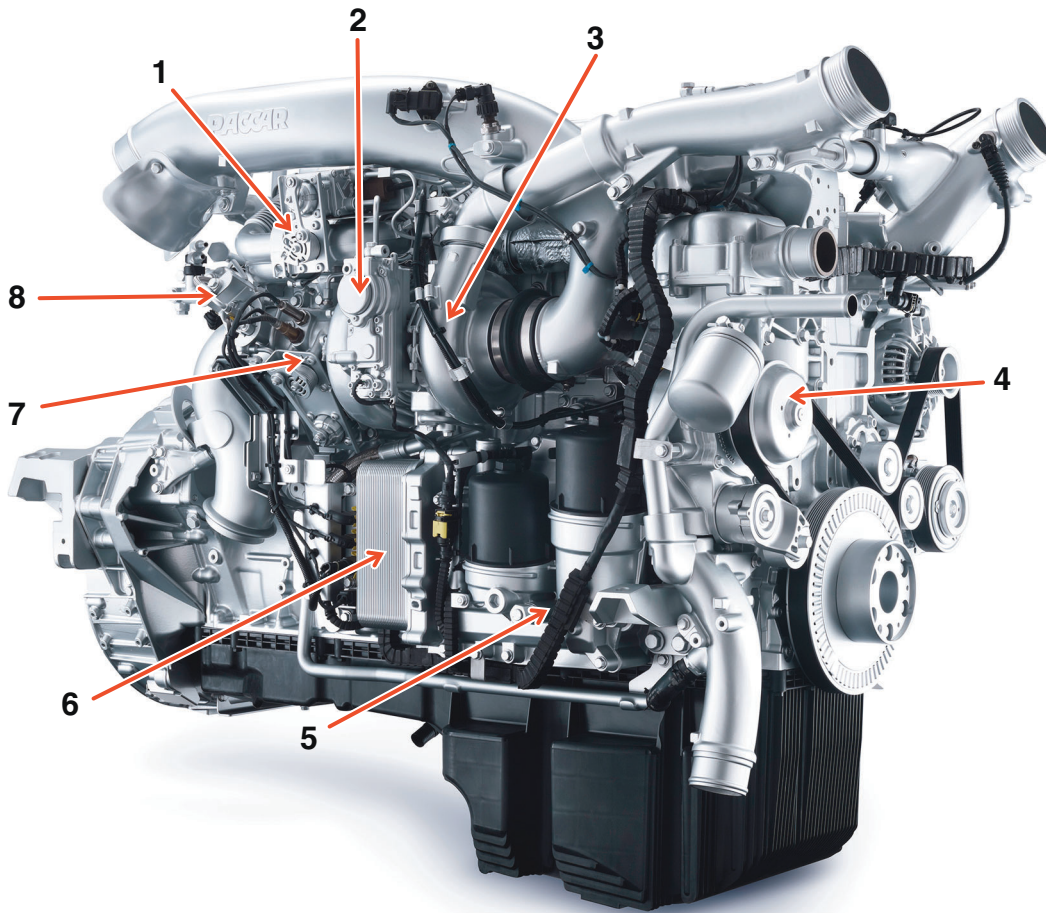

i402147

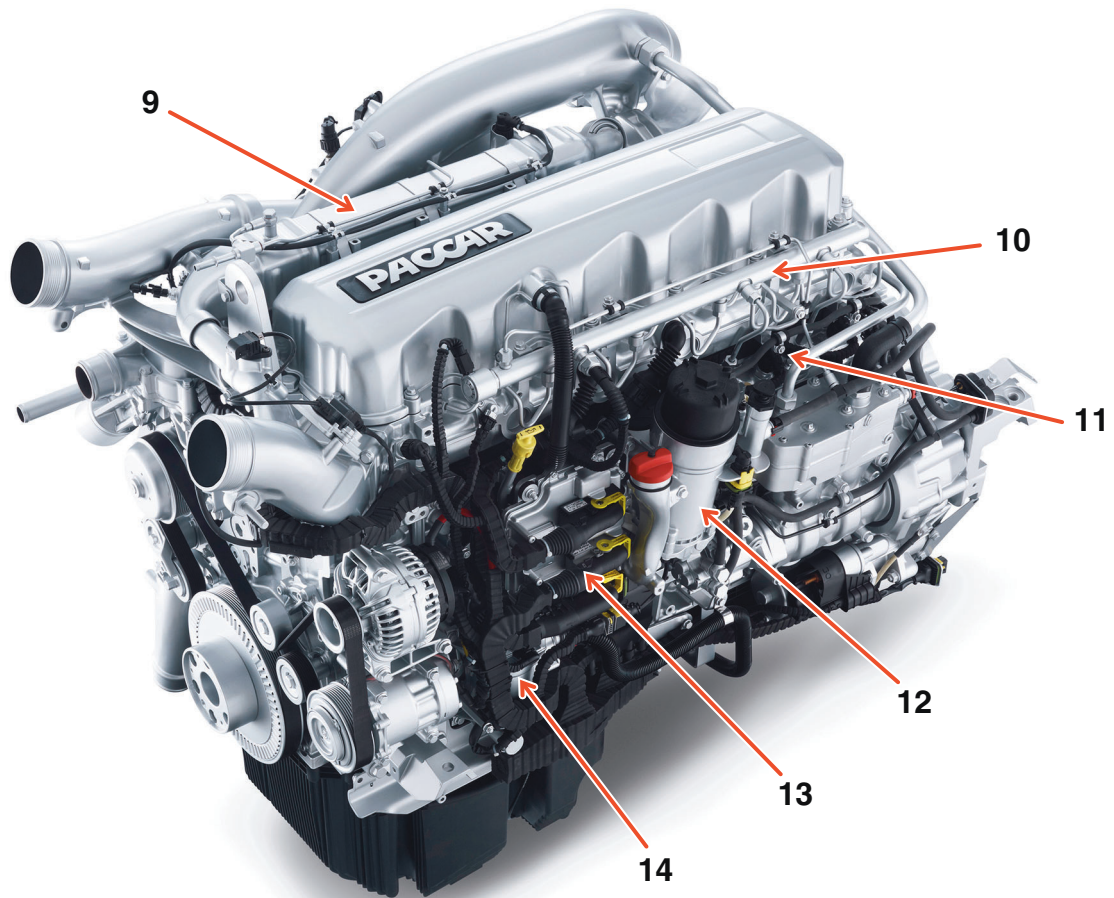

- 1 EGR valve (L095)
- 2 Rotary speed actuator (L037)
- 3 VTG
- 4 Coolant pump
- 5 Oil module
- 6 Oil cooler
- 7 BPV (L096)
- 8 Fuel dosing valve (L124)
- 9 EGR Cooler
- 10 Common rail
- 11 Common rail pump unit (L092 , L093)
- 12 Fuel filtration module
- 13 ECU
- 14 Crankcase ventilation module (L090)

i402148

# BASIC ENGINE

---

## Introduction



1

.....

.....

.....

.....

.....

.....



## 2. COMPONENTS

### 2.1 ELECTRONIC CONTROL UNIT PCI

#### PACCAR Common rail Injection (PCI)

The main task of the PCI engine management system is to control the engine so it runs as smooth and efficient under all possible circumstances. An in-depth description of the functions and controls of the PCI is covered in a separate module. The heart of the PCI is the electronic control unit (ECU), a sophisticated computer which contains electronic power supplies, central processing units, memory, sensor input circuits, and output driver circuits. On some equipment the ECU may communicate with other electronic controls via the CAN network. The ECU functions as the electronic governor controlling the fuel system. The ECU receives input signals from the sensors and other systems like EAS (Emission Aftertreatment System). The ECU energises the solenoids from the injectors and common rail pump units to control timing and engine speed accurately.

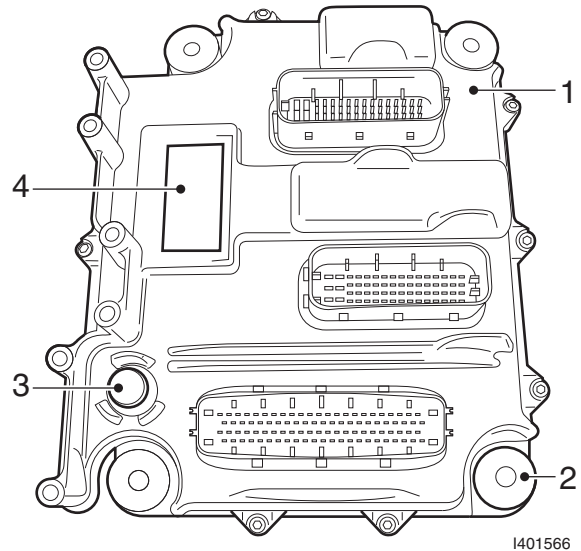

I401566

The electronic control unit is mounted on the cylinder block with rubber insulating bushes (2). The electronic control unit has two 62-pin connectors and a 92-pin connector. Input signals from various sensors are continuously processed and compared with data stored in various maps (tables) in the electronic control unit. Actuators are energised on the basis of the signals received and the maps. The housing (1) of the electronic control unit is directly connected to the engine block. The electronic control unit incorporates an atmospheric pressure sensor and a temperature sensor. There is an air vent (3) for the atmospheric pressure sensor in the housing of the electronic control unit. An identification sticker (4) is attached to the electronic control unit.



*What factors determine energising of the actuators?*



.....

.....

.....

.....

.....

.....

# BASIC ENGINE

## Components

### 2.2 CYLINDER HEAD AND VALVE COVER

#### Cylinder head

- 1 Cylinder head
- 2 Valve bridge
- 3 Spring cap
- 4 Valve spring
- 5 Valve spring
- 6 Valve spring
- 7 Valve stem seal
- 8 Inlet valves
- 9 Outlet valves

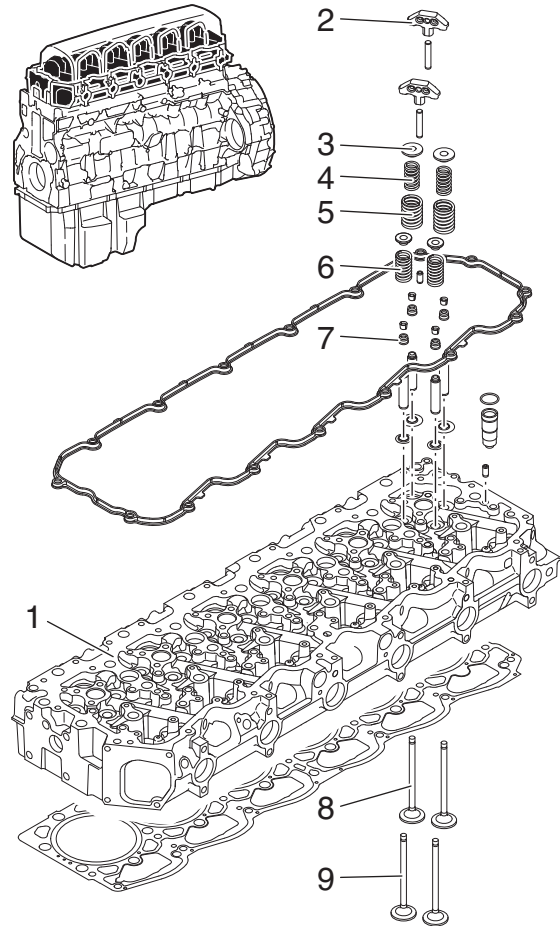

The cylinder head is a one-piece cylinder head, made of compact graphite iron with integrated high pressure lines to feed the injectors. Four valves are used per cylinder, actuated from a camshaft that is positioned in the cylinder block. The inlet manifold is integrated in the cylinder head.

The cylinder head is mounted to the cylinder block with a steel multi-layer gasket.

i402054

#### Valve cover

The valve cover covers the valves and is made of cast aluminium. The crankcase gases collect here and led through a labyrinth before being discharged to the crankcase ventilation module.



How many valves per cylinder are fitted?



.....

.....

.....

.....

.....

.....

**2.3 PISTONS AND LINERS**

**Piston**

The one-piece pistons are made of steel with a closed gallery. The arrow on the piston must point towards the front of the engine. Oil jets cool the pistons by spraying a large amount of oil into the piston gallery in the piston head. The gallery is equipped with holes through which the oil is supplied and discharged back to the oil sump.

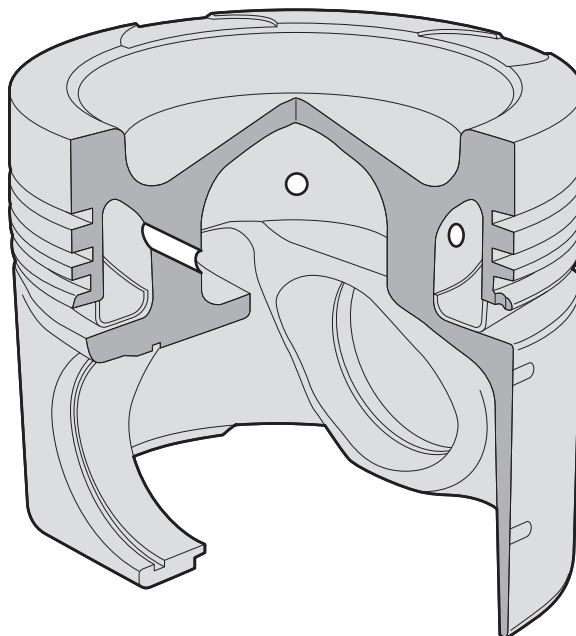

**1**

**Liner**

The cylinder liners (3) contain an anti-polishing ring (2). This ring has a slightly smaller inner diameter compared to the cylinder liner and prevents carbon build-up on the upper part of the piston (1). Any such deposits are harmful since they disturb the oil film on the cylinder liner, which again leads to liner polishing. The anti-polishing ring (APR) does not need to be specifically fixated, as it is kept perfectly and tightly in place by thermal expansion.

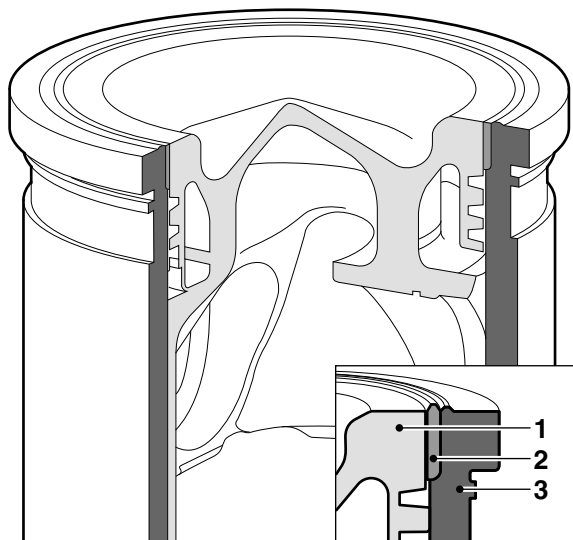

# BASIC ENGINE

## Components

- 1 Anti-polishing ring
- 2 Liner
- 3 D-ring - oil resistant
- 4 D-ring - coolant resistant

Wet cylinder liners are used. D-rings seal against coolant leakage.



*What method is used to secure fixation of the anti-polishing ring?*

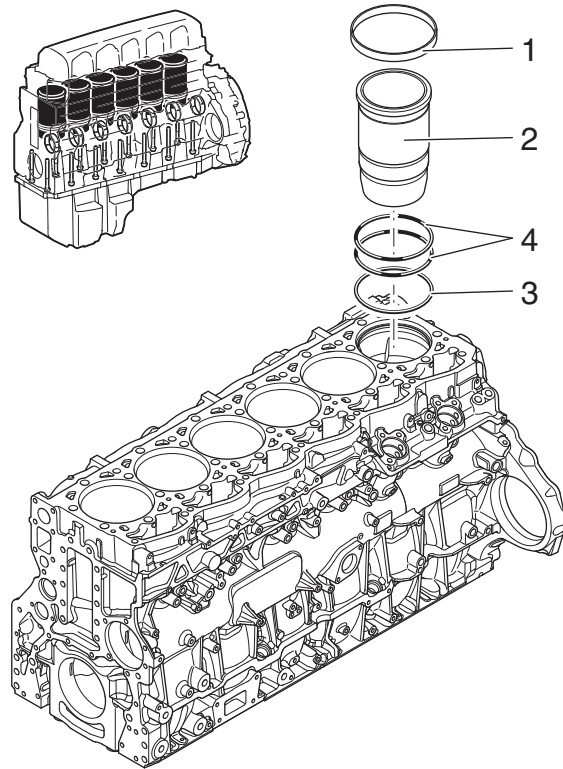

i402055

.....

.....

.....

.....

.....

.....

**2.4 CRANKSHAFT AND BEARINGS**

**Crankshaft**

- 1 Crankshaft
- 2 Crankshaft main bearing shell
- 3 Crankshaft main bearing shell
- 4 Thrust washer crankshaft

The engine has a crankshaft with seven bearings. The thrust bearing of the crankshaft is placed on the 7th main bearing. The crankshaft has no balance weights. For a correct balance the crankshaft journals have holes drilled in them. The vibration damper is attached to the attachment flange at the front of the crankshaft. The drive gear drives the camshaft and the air compressor via the idler gear. The crankshaft gear wheel drives the oil pump directly. The flywheel is fitted on the attachment flange, which is pressed on the crankshaft.

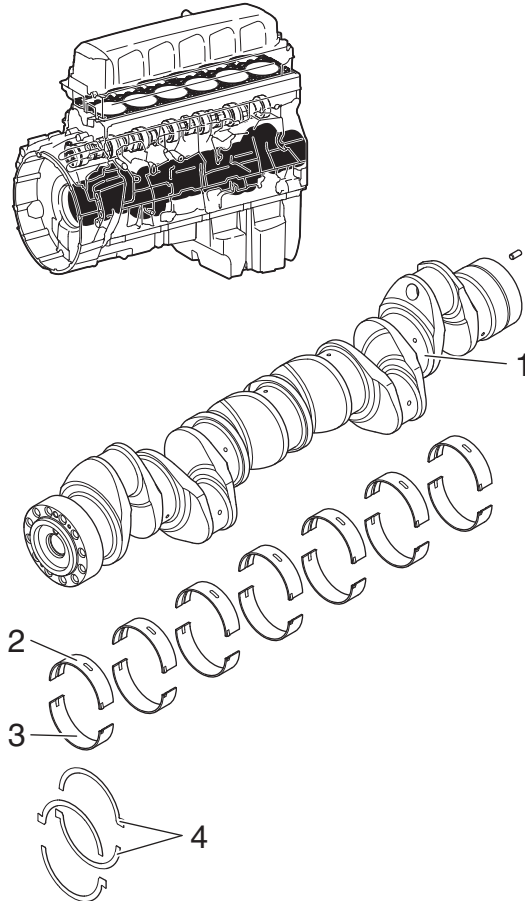

i402056

**Engine block**

The engine block is made of compact graphite iron (CGI). The main bearings (7) are split fractured to keep the machining of the bearings exact. Die cast numbers on the main bearing caps and in the lower block indicate the proper position. Thrust bearings mounted on the seventh main bearing cap absorb clutch forces.

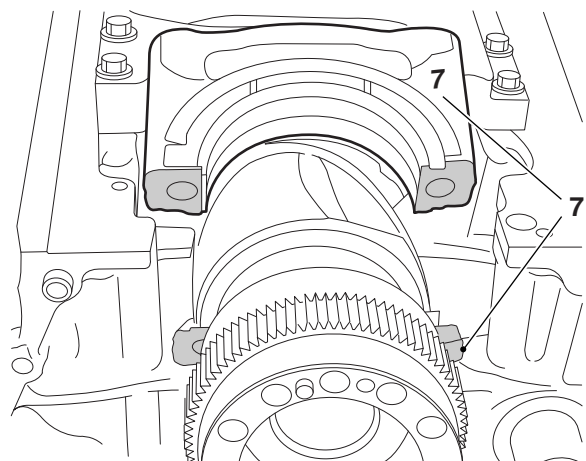

M201490-2

# BASIC ENGINE

## Components

### Bearings

The connecting rods are split fractured to keep the machining of the bearings exact. This process also provides a much bigger mating surface between the parts (1). Care must be taken when handling the main bearing cap and the connecting rod and rod caps, to prevent damage to the mating surface. Each cap is marked with an identification that must be matched with its original position.

1

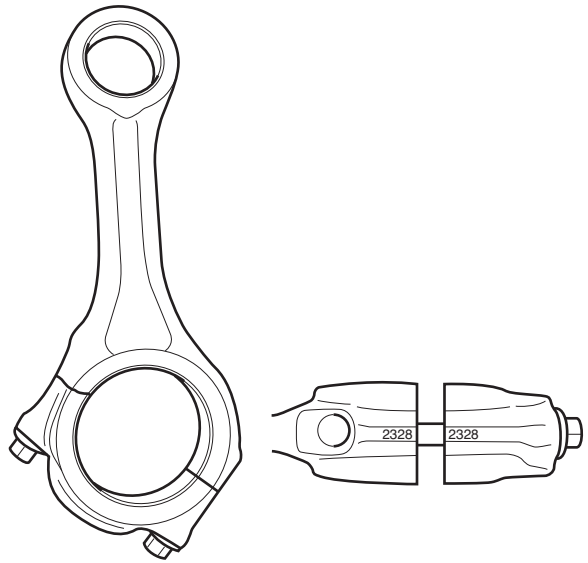

M201509-2



On which main bearing are the thrust washers positioned?

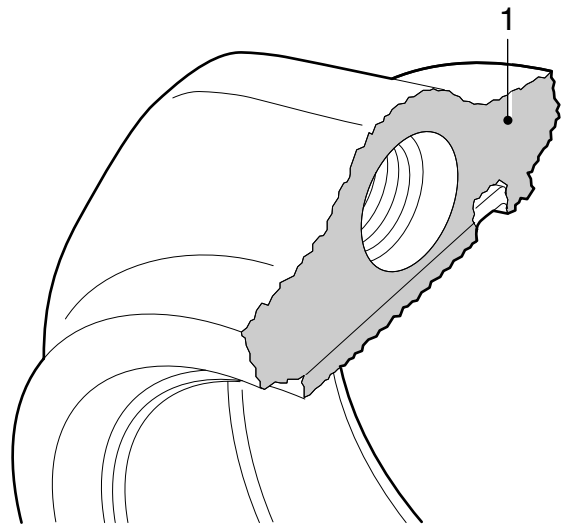

M201510

.....

.....

.....

.....

.....

.....

## 2.5 CAMSHAFT

- 1 Camshaft
- 2 Locking plate

The camshaft is driven by the crankshaft via the idler gear. By using a dowel pin, the drive gear can only be fitted on the camshaft in one position.

Cam A1 to A6 actuate the intake valves; B1 to B6 actuate the exhaust valves. C5 and C6 are three-lobed cams that actuate the pump units for the common rail system.

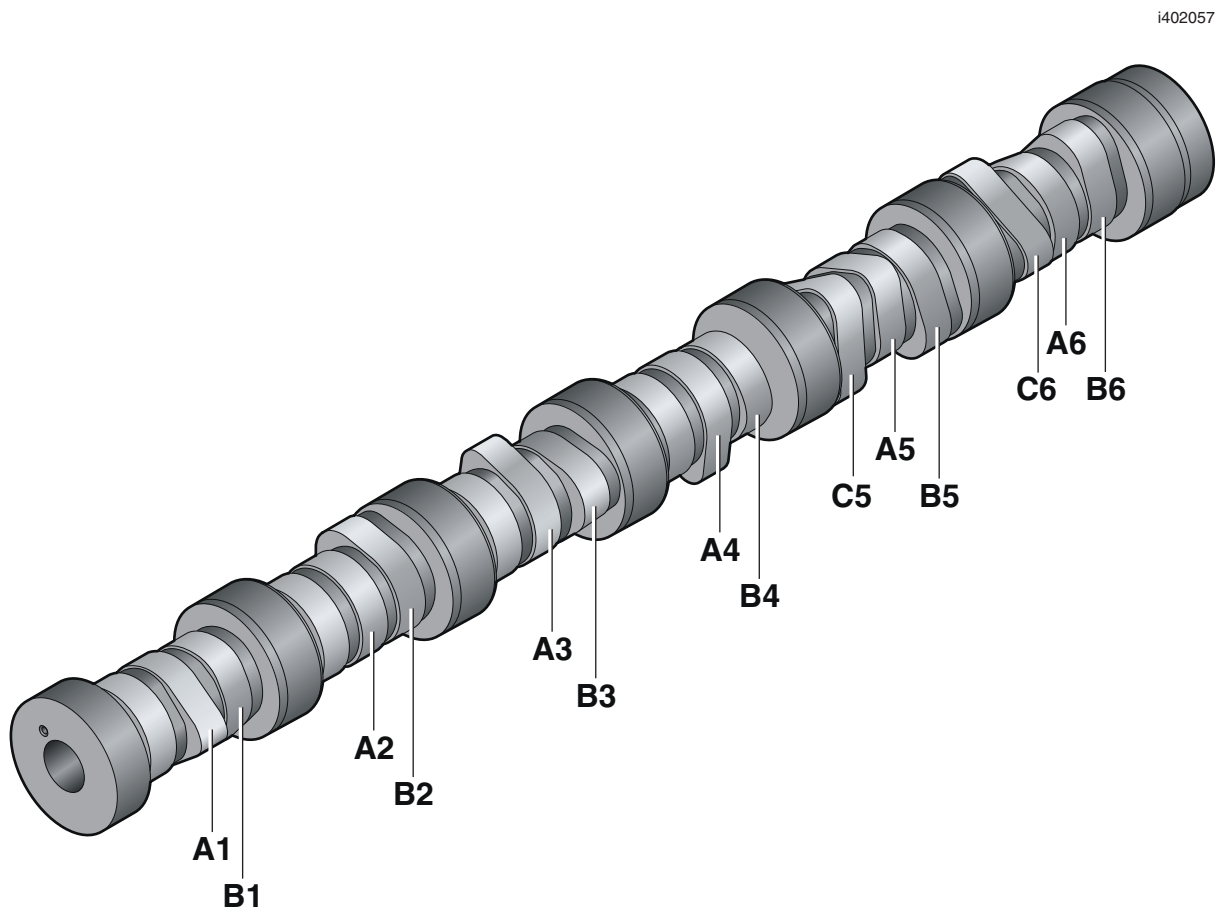
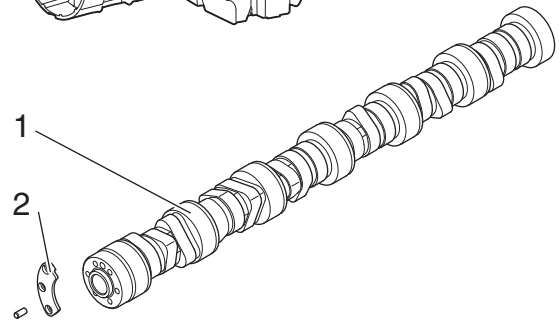
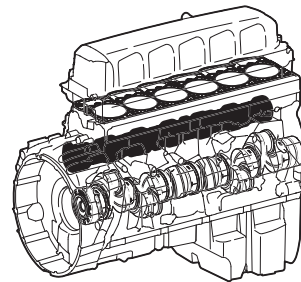

i402057

i401968-2

# BASIC ENGINE

---

## Components



*What is the shape of cam C5 and C6 in the drawing?*

1



.....

.....

.....

.....

.....

.....



**2.6 GEAR TRAIN**

- 1 Idler timing gear
- 2 Hub, idler timing gear
- 3 Pulse ring
- 4 Camshaft gear
- 5 Vibration damper
- 6 Plug
- 7 Crankshaft gear

The camshaft, compressor and auxiliaries are driven by gears at the flywheel side of the engine. Via the idler gear (1), the crankshaft gear wheel (7) drives the camshaft drive gear (4) and the air compressor. The crankshaft gear directly drives the oil pump gear.

A PTO (Power Take Off) is installed, depending on the application of the engine.

A vibration damper (5) is installed at the front end of the crankshaft to reduce vibrations.



**True or false:** the gears are positioned at the flywheel side of the engine.



.....

.....

.....

.....

.....

.....

.....

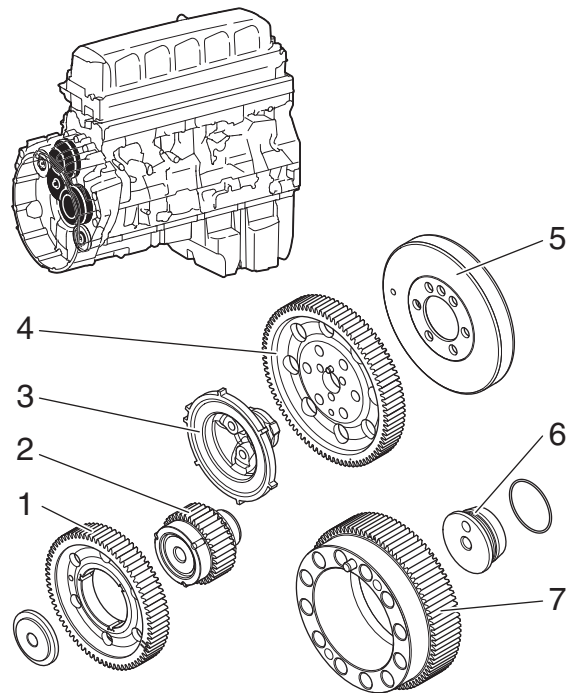

i402058

## BASIC ENGINE

---

### Components

#### 2.7 OIL SUMP

1

The bottom of the engine block has a sump reinforcement plate. This reinforcement plate stiffens the construction of the bottom of the engine block, so the engine produces less noise.

The sump is made of special reinforced polymer material. The sump is bolted directly to the engine block flange with pre-mounted bolts with metal inserts (detail A). The gasket is pre-mounted in a groove (detail B). The sump is equipped with a bayonet drain plug (C) and an oil level sensor (D).

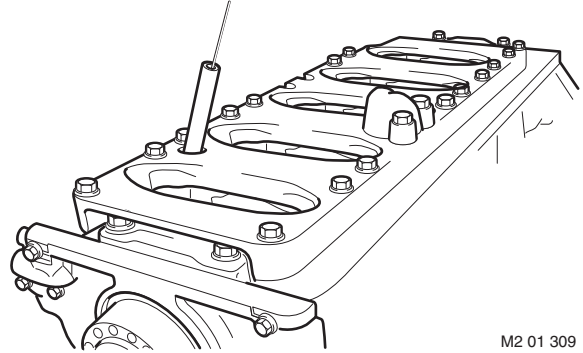

M2 01 309

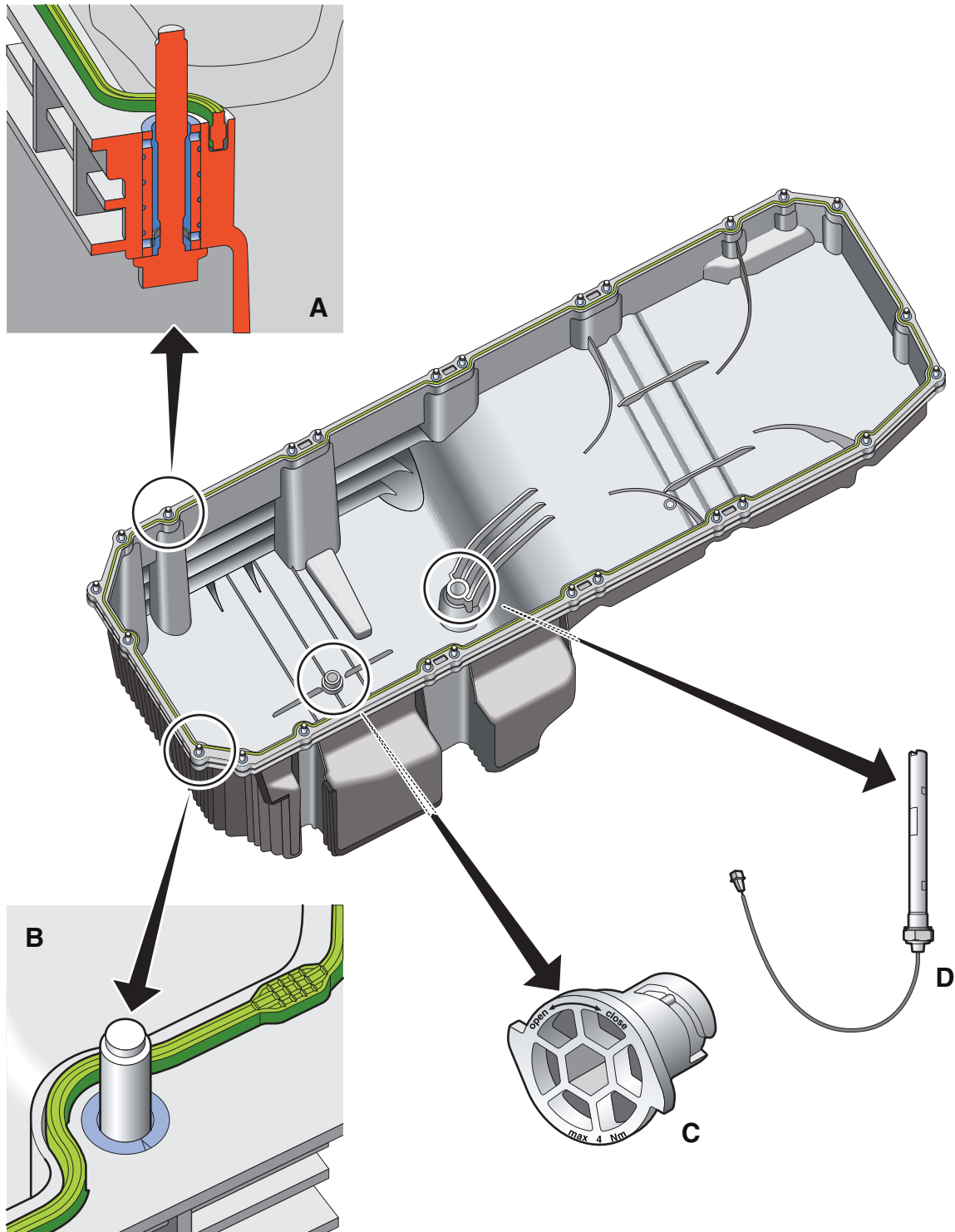

i402059

# BASIC ENGINE

---

## Components



**True of false:** The oil sump is mounted directly to the sump reinforcement plate.

1



.....

.....

.....

.....

.....

.....

**2.8 CRANKCASE VENTILATION MODULE (L090)**

**1**

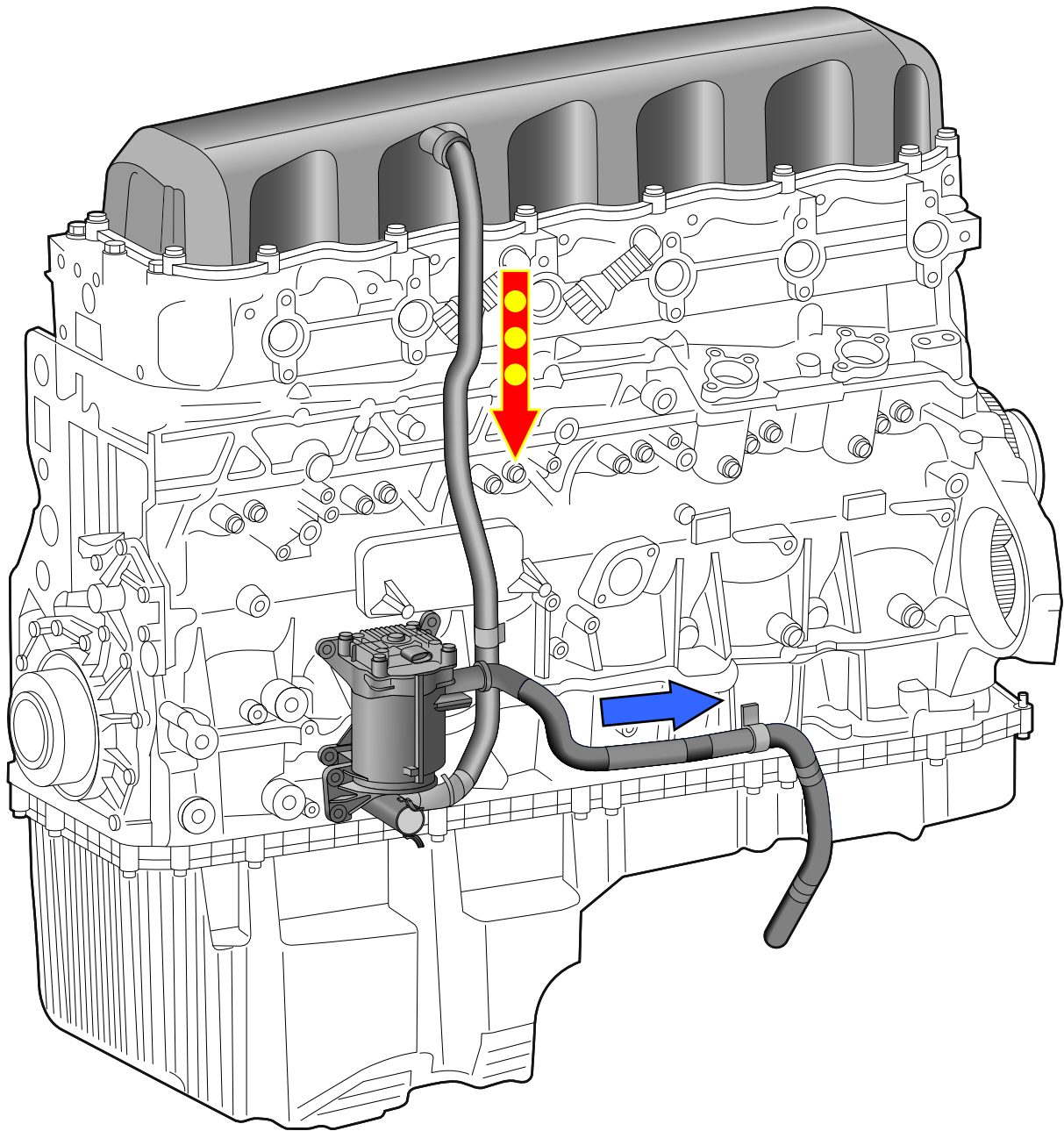

i402052

## BASIC ENGINE

### Components

1

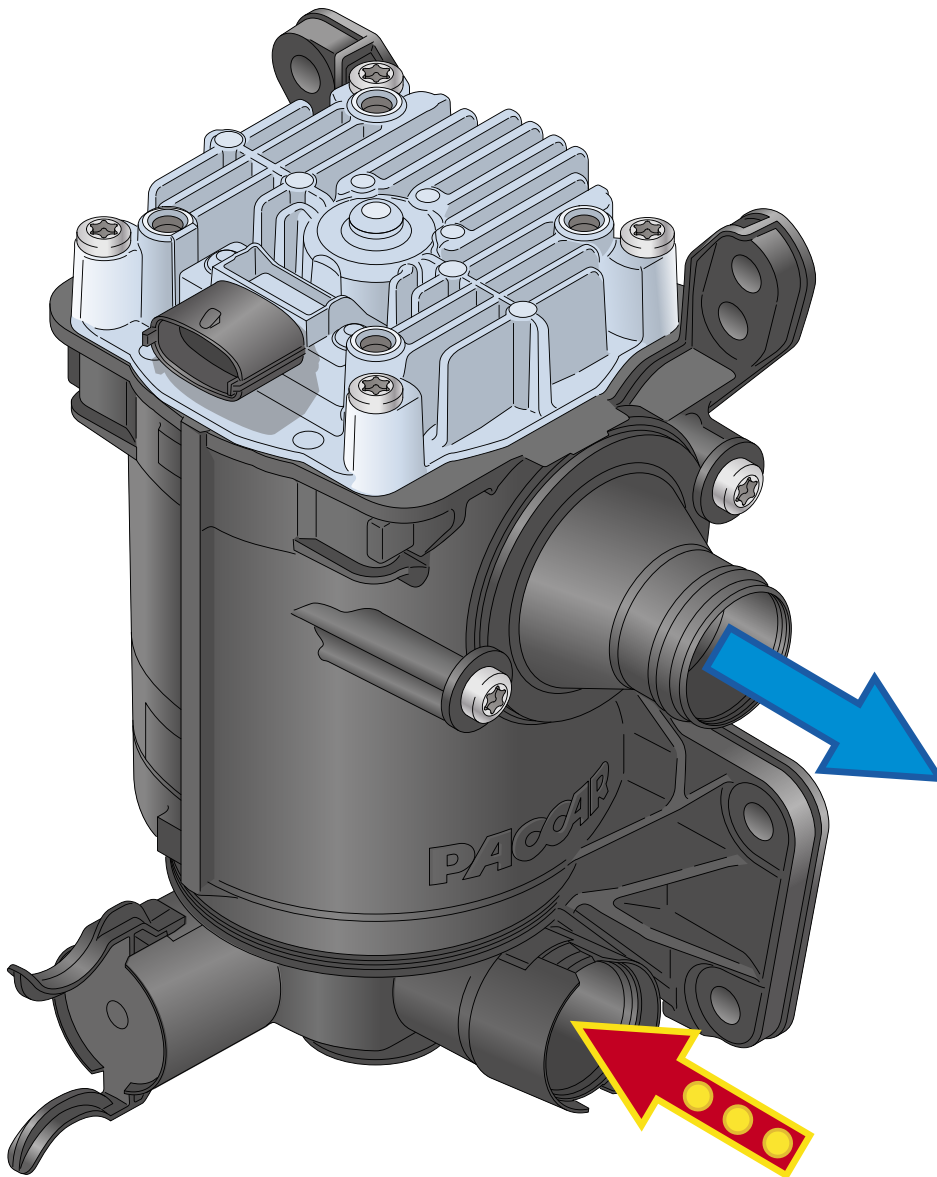

i401936

#### Overview

All engine combustion processes produce exhaust gases. A small portion leaks from the combustion chamber down into the crankcase where the exhaust gases mix with oil and turn into crankcase gases. These gases must be discharged constantly to prevent pressure building up inside the crankcase. The emission of oil (airborne and oil borne) coming out of the crankcase ventilation, is restricted to certain values (demands by several governmental rules). The crankcase ventilation module must be able to remove oil out of the crankcase gas stream to a certain amount. When the gases leave the module they flow back to the environment.

A crankcase ventilation module protects both engine and environment. The stringent Euro 6 emission limits prohibit that blow-by gases which are loaded with oil mist are discharged into the environment in an unclear form. The crankcase ventilation module performs these required cleaning functions and returns the separated engine oil to the oil sump. The cleaned gas is compliant with the emission regulations and can be transported to the environment.

### Operation

The crankcase ventilation module is based on the centrifuge principle. Crankcase gas, that contains a certain amount of oil mist, enters the module at the lower connection (red arrow). An electrical driven, internal element with 98 circular discs rotates at 12.000 rpm, separates the heavier oil mist from the crankcase gas.

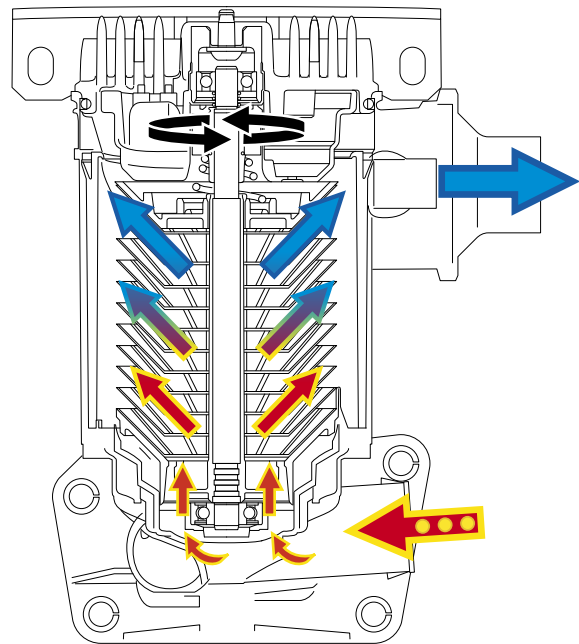

i401945-2

## BASIC ENGINE

### Components

- Red arrow      Crankcase gas entering module
- Blue arrow     Cleaned gas exiting module
- Yellow arrow   Oil back to sump

1

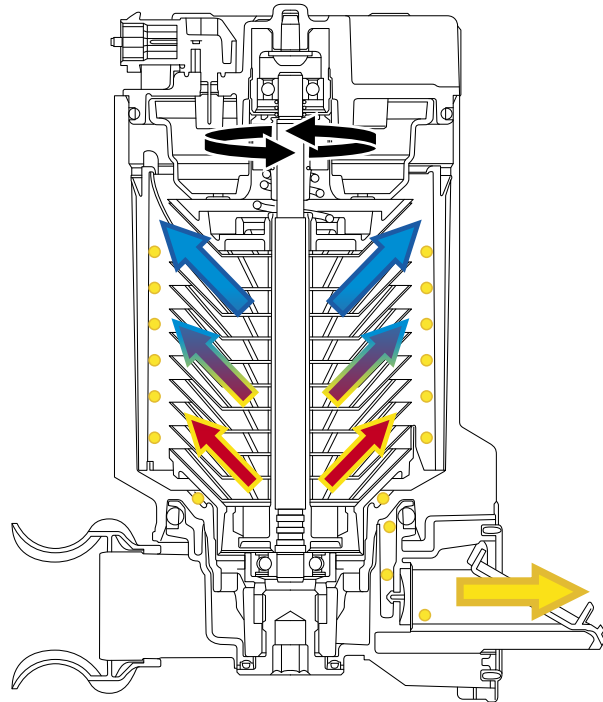

i401937-2

The separated oil is thrown outwards against the wall, drops down and is collected in the lower part of the housing. From there the oil drains back to the oil sump via the drain valve and the connection (yellow arrow). The connection is covered to prevent oil splashing from the sump into the connection.

The cleaned gas leaves the module at the top connection (blue arrow) and flows to the road draft tube. The crankcase ventilation module is maintenance-free. For diagnostic purposes the rotating element has a speed sensor (Hall-sensor) that reads the magnet of the motor to provide feedback on its operation to the PCI ECU.





*What is the shape of the elements that actually separate the oil from the crankcase gas?*

*What type of speed sensor is used to monitor the rotation speed of the element?*



.....

.....

.....

.....

.....

.....

## **BASIC ENGINE**

---

### Components

**1**

# FUEL SYSTEM

## Contents

### CONTENTS

	Page	Date
<b>1. INTRODUCTION</b> .....	1-1	201243
1.1 System introduction .....	1-1	201243
<b>2. SYSTEM</b> .....	2-1	201243
2.1 Overview Fuel system .....	2-1	201243
2.2 Fuel supply system .....	2-3	201243
2.3 Low pressure system .....	2-4	201243
2.4 High pressure system .....	2-5	201243
2.5 Fuel Return lines .....	2-9	201243
<b>3. COMPONENTS</b> .....	3-1	201243
3.1 Fuel lift pump .....	3-1	201243
3.2 Fuel filtration module .....	3-2	201243
3.3 Pump unit, Common rail, injector .....	3-9	201243

# FUEL SYSTEM

---

## Contents

2

# 1. INTRODUCTION

## 1.1 SYSTEM INTRODUCTION

The fuel system consists of a fuel supply system, a fuel filtration module, a high pressure system and a fuel return system.

The fuel supply system transports the fuel from the tank to the fuel filtration module. The fuel filtration module has multiple tasks such as filtering and heating of the fuel and separating water from the fuel.

The high pressure system is used to pressurise and inject the fuel in the combustion chamber under high pressure.

The return system transports the excess amount of fuel back to the tank or fuel filtration module.



.....

.....

.....

.....

.....

.....

# FUEL SYSTEM

---

## Introduction

2

**2. SYSTEM**

**2.1 OVERVIEW FUEL SYSTEM**

**Fuel system MX-13 engine**

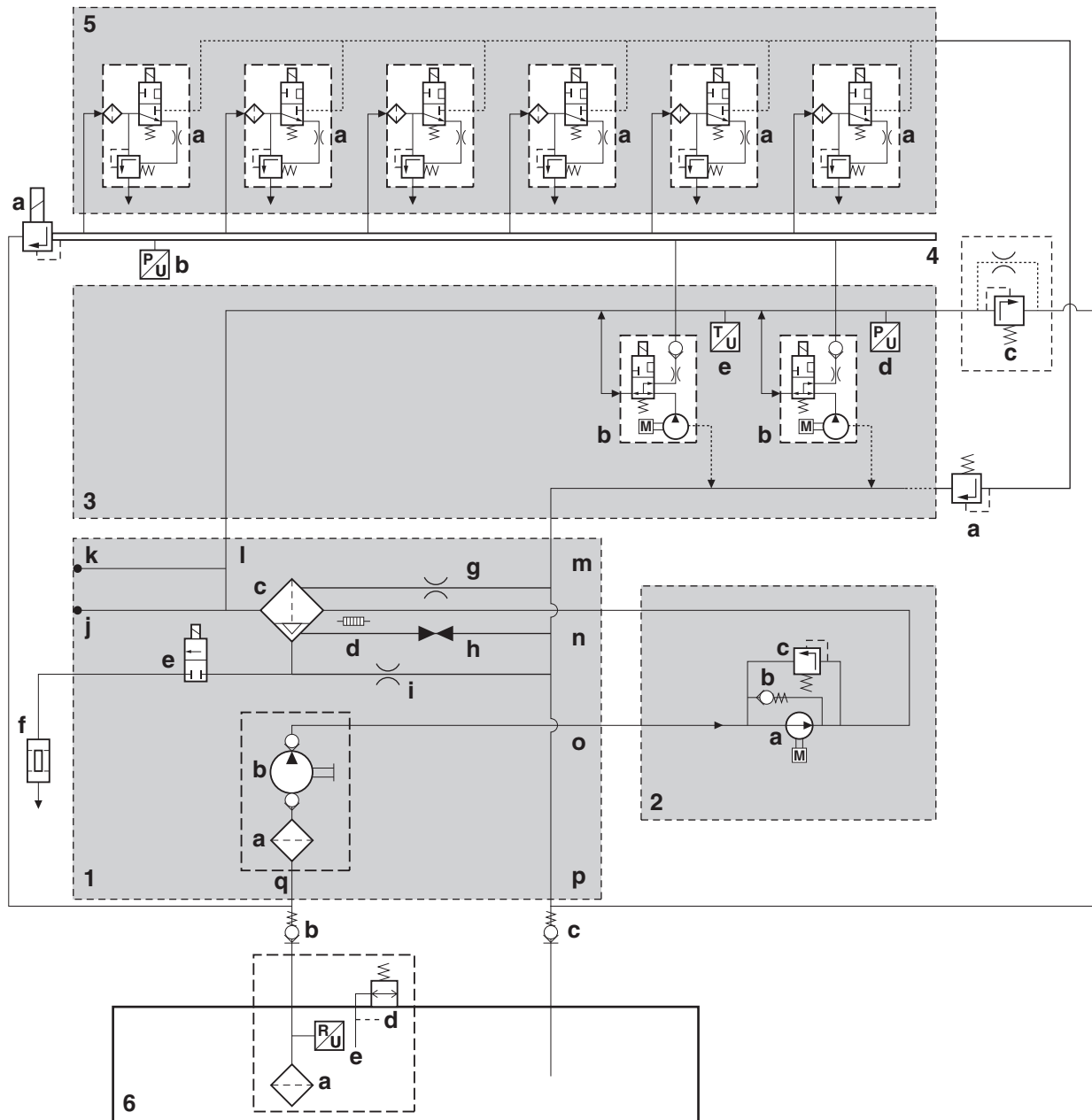

- 1 Fuel Module
- 1a Fuel sieve
- 1b Hand priming pump
- 1c Filter element and water separator
- 1d Fuel heater
- 1e Water drain valve - Water in Fuel Sensor
- 1f Activated carbon canister
- 1g Deaeration filter (circulation)
- 1h Drain line (filter change)

i401926

## FUEL SYSTEM

---

### System

- 1i Water overflow (redundancy)
- 1j Test connection fuel pressure
- 1k Supply fuel EAS - Fuel dosing valve
- 1l Fuel connection to gallery
- 1m Fuel return from gallery
- 1n Fuel inlet from lift pump
- 1o Fuel to lift pump
- 1p Fuel return to tank
- 1q Fuel inlet
- 2 Fuel lift pump
- 2a Pump unit
- 2b Non-return valve
- 2c Safety valve
- 3 Cylinder block
- 3a Injector back leak valve
- 3b High pressure pump units
- 3c Fuel pressure regulating valve
- 3d Pressure sensor
- 3e Temperature sensor
- 4 Common rail
- 4a Common rail pressure relief valve
- 4b Pressure sensor
- 5 Cylinder head
- 5a Injector
- 6 Fuel tank
- 6a Tank Sieve
- 6b Coupling supply line
- 6c Coupling return line
- 6d Pressure valve
- 6e Tank level sensor

2



### 2.2 FUEL SUPPLY SYSTEM

#### Fuel supply

The fuel from the tank (6) enters the fuel filtration module via shut-off valve (6b) in the supply pipe. A tank sieve (6a) and a filter in the hand priming pump prevent any larger impurities from the bottom of the fuel tank getting into the fuel system. The return fuel from the fuel filtration module flows back to the tank via a shut-off valve (6c). The shut-off valves (6b and 6c) are opened when the fuel lines are connected. When the fuel lines between engine and chassis are disconnected, the valves close.

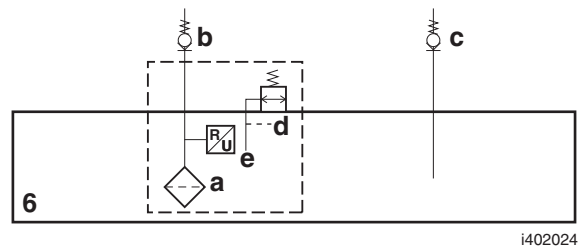

The tank is equipped with a level sensor (6e) and a pressure valve (6d) in the filler cap.



.....

.....

.....

.....

.....

.....

.....

# FUEL SYSTEM

## System

### 2.3 LOW PRESSURE SYSTEM

The low pressure fuel supply system consists of a fuel lift pump and a fuel filtration module.

#### Fuel lift pump

The fuel lift pump transports the fuel from the tank to the fuel filtration module.

#### Fuel filtration module

The fuel enters the fuel filtration module at the hand priming pump (1b). It flows via connection (1o) to the fuel lift pump and enters the fuel filtration module again at (1n). Fuel passes via the integrated fuel heater (1d) through the fuel filter element (1c) and automatic water separator which is part of the filter element. The separated water is collected and the level is sensed by a water-in-fuel sensor that activates the automatic drain valve (1e). The water is discharged to the environment via an activated Carbon Filter (1f). An orifice in the water separator (1i) deaerates the water bowl, an orifice in the filter (1g) deaerates the filter, both lines are connected to the return fuel gallery (1m). The outlet for the clean fuel (1l) is directly connected to the fuel gallery in the cylinder block. There is a test connection on the fuel filtration module for measuring the fuel pressure (1j). The solenoid valve on the fuel intake module controls the fuel supply to the fuel dosing valve of the EAS-3. The dosing module injects fuel in the exhaust during the active regeneration process. Clean fuel is supplied by the fuel filtration module through a direct connection (1k) but the solenoids are controlled by the ECU of the Emission Aftertreatment System (EAS-3).

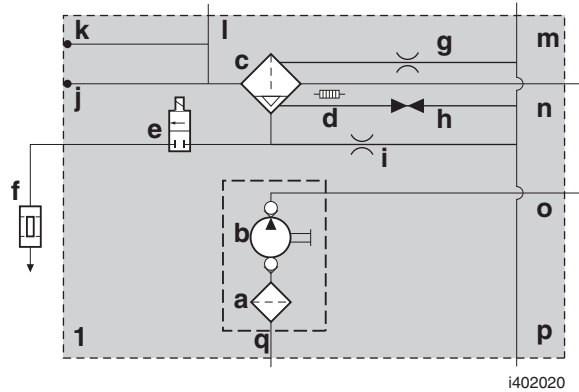

2



.....

.....

.....

.....

.....

.....

**2.4 HIGH PRESSURE SYSTEM**

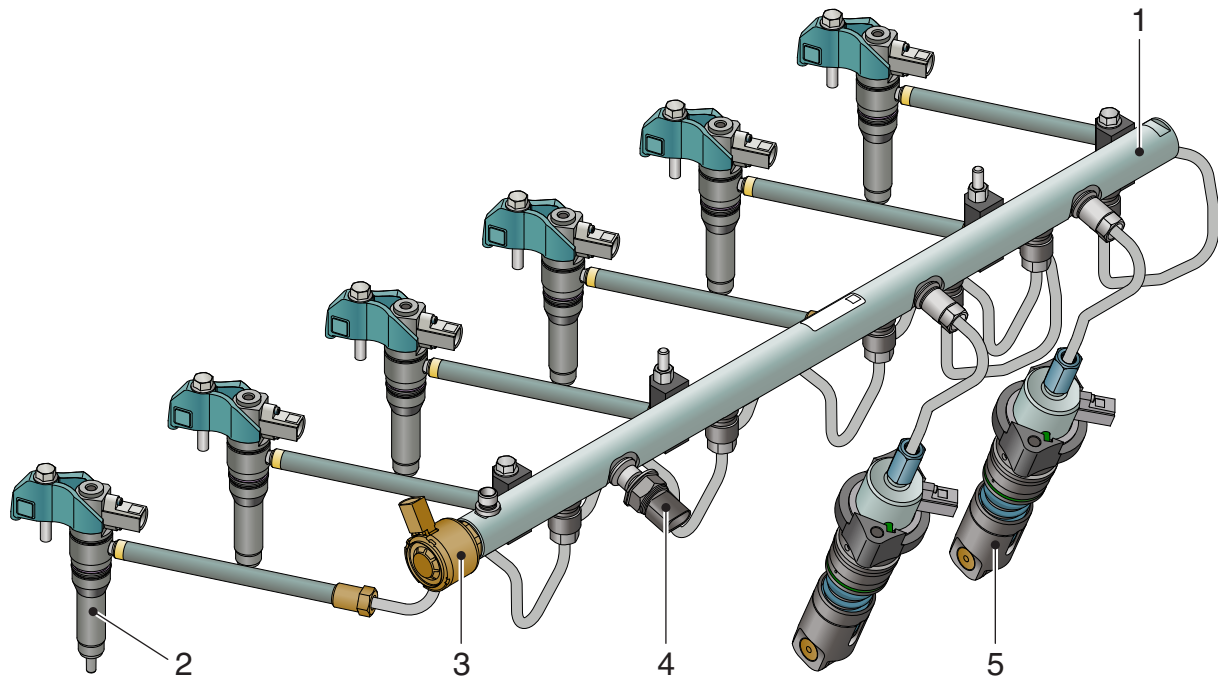

**2**

- 1 Common rail
- 2 Injector (B421 - B426)
- 3 Common rail pressure relief valve (L094)
- 4 Pressure sensor (F854)
- 5 Common rail pump unit (L092, L093)

i401932

The high pressure system comprises of a high pressure fuel accumulator (common rail, 1) which is connected to 6 injectors (2), fitted into the cylinder head. Two electronic controlled unit pumps (5) are fitted into the engine block to supply high pressure fuel to the common rail. The pressure in the rail is controlled by the common rail pressure release valve (3) and measured by a pressure sensor (4).

The high pressure in the system is delivered by two pump units that are mounted in a special gallery in the casting of the cylinder block. Two tappets are mounted within the pump bores of the engine block, and the tappet rollers contact the cam surface. The pump units are pressure lubricated by the oil system.

# FUEL SYSTEM

## System

2

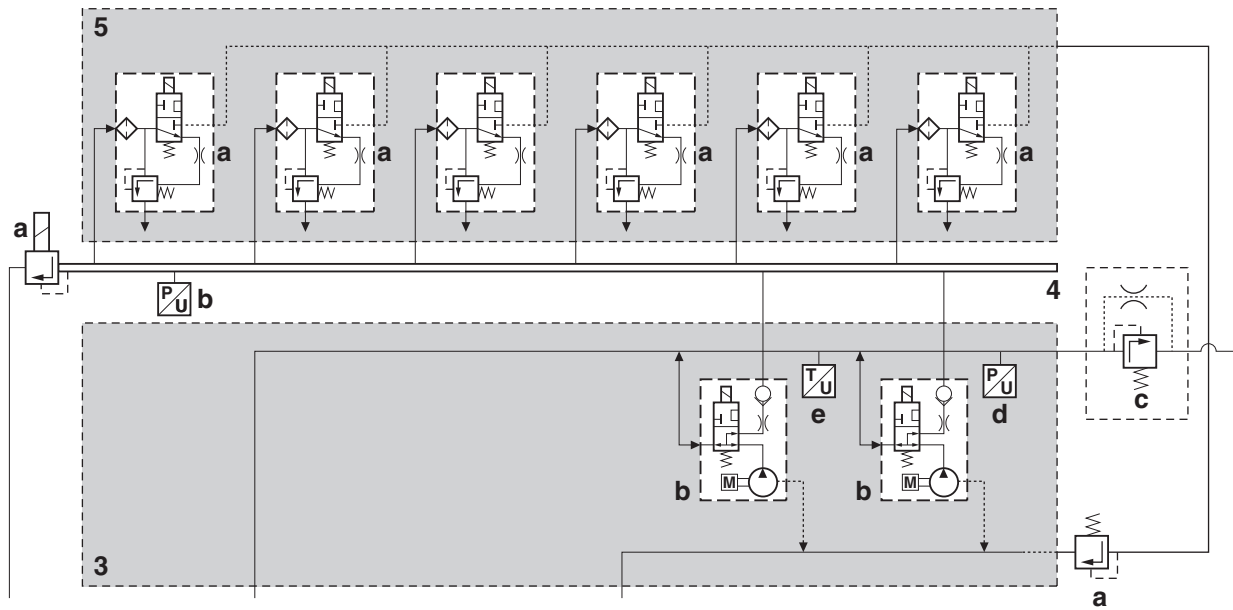

i402023

- 3 Cylinder block
- 3a Injector back leak valve
- 3b High pressure pump units
- 3c Fuel pressure regulating valve
- 3d Pressure sensor
- 3e Temperature sensor
- 4 Common rail
- 4a Common rail pressure relief valve
- 4b Pressure sensor
- 5 Cylinder head
- 5a Injector



.....

.....

.....

.....

.....

.....

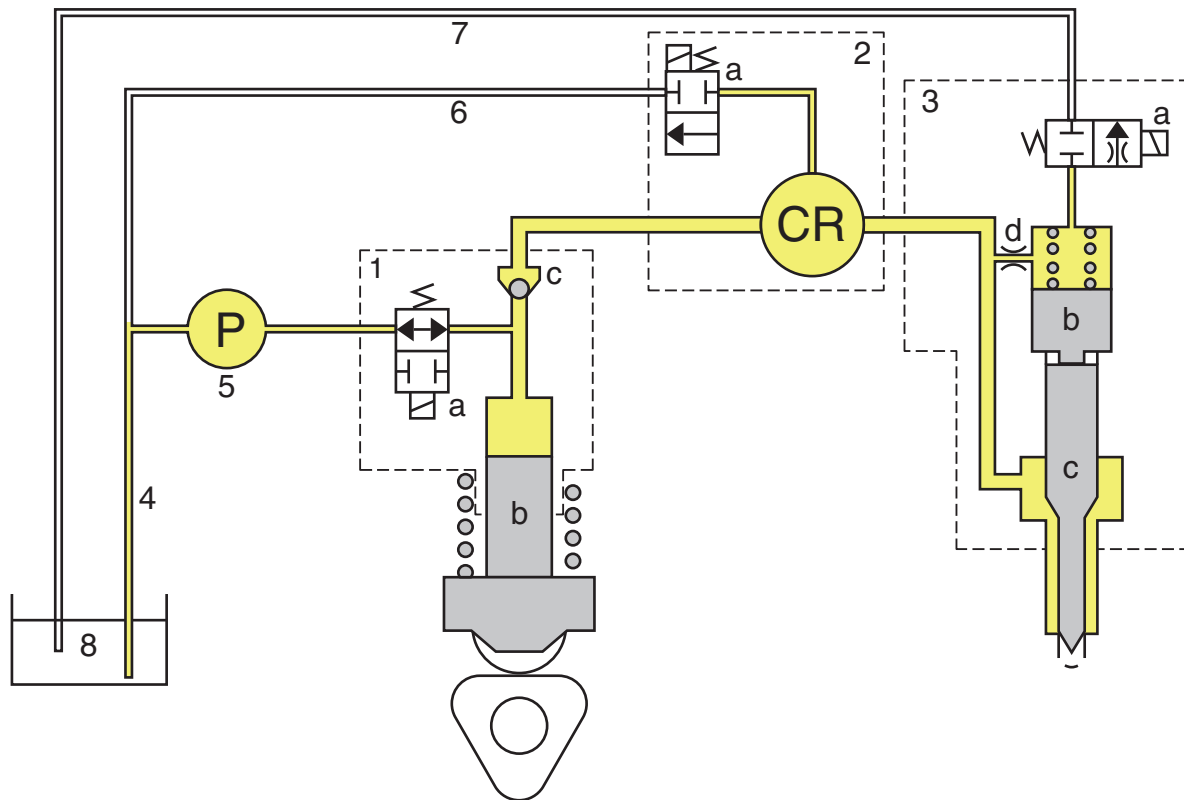

- 1 Pump unit
- 1a Outlet metering valve
- 1b Plunjer
- 1c Check valve
- 2 Common rail with pressure release valve (L094)
- 3 Injector with solenoid
- 4 Fuel supply line
- 5 Fuel lift pump
- 6 Return fuel from common rail pressure release valve
- 7 Return fuel from injector
- 8 Fuel tank

I401982

The fuel is transported from the tank (8) via the supply line (4) and fuel lift pump (5) to the high pressure pump unit (1). If the outlet metering valve in the pump unit is not activated, the fuel is pumped back into the fuel supply line. When the outlet metering valve in the pump unit is activated, the return is closed and the fuel is pumped at high pressure to the common rail (2) through the checkvalve (1c). When the ECU activates the solenoid valve in the injector (3) an injection takes place.

The ECU controls the solenoids from the injectors (3a), the outlet metering valves from the pump units (1a) and the common rail pressure relieve valve (2a) to affect the pressure in the rail. The regulation of the pressure in the rail is carried out by actuating the outlet metering valve located

## FUEL SYSTEM

---

### System

within the high pressure pump. The discharge of the rail pressure, during large drops in rail pressure demand, is carried out by the common rail pressure release valve (2a). The outlet metering valve pulse demand and the common rail pressure release valve current demand are computed depending on the total rail pressure demand, rail pressure feedback, rail pressure error, engine speed, fuel quantity demand. The rail-mounted pressure sensor monitors the fuel pressure in the rail.

2



*What happens to the fuel when the outlet metering valve is not activated?*



.....

.....

.....

.....

.....

.....

**2.5 FUEL RETURN LINES**

**Return lines**

There are four return systems distinguishable:

- Leak off from injectors
- Leak off from common rail pressure release valve
- leak off from fuel gallery
- Return line from fuel filtration module

These four systems have in common that they supply a path for fuel that is not used for the combustion but has been transported into the low or high pressure system. For several reasons the fuel must be transported out of these systems and led back to fuel filtration module or fuel tank.

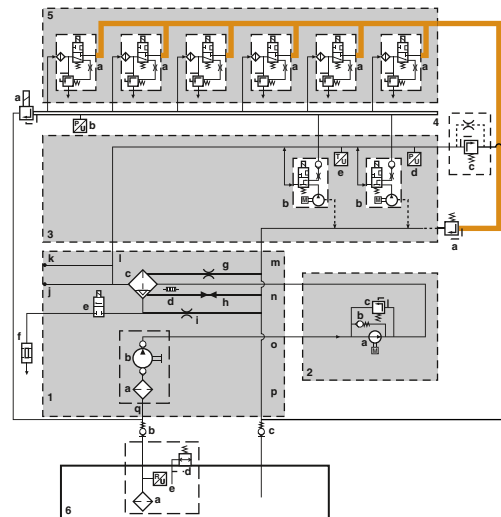
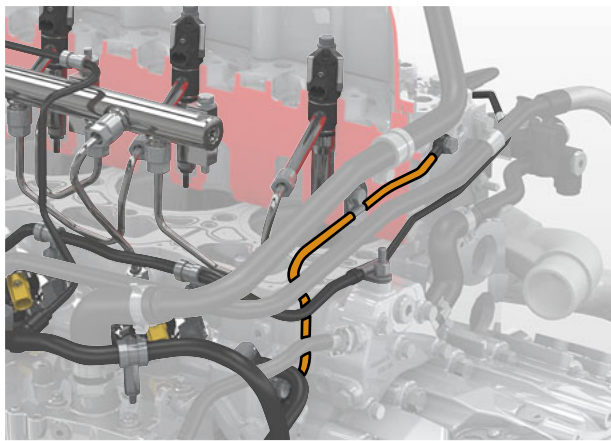

Leak off from injectors: fuel flows from a gallery in the cylinder head and an external steel line to the fuel return gallery in the engine block. The connection is equipped with a non-return pressure valve (3a). The non-return pressure valve serves to prevent fuel entering the cylinder if an injector is pulled when there is still pressure on the fuel tank. The other function of the non-return valve is to keep the return gallery in the cylinder head filled with pressurised fuel (600 - 750 kPa) to prevent cavitation in the injectors.

i402036

# FUEL SYSTEM

## System

2

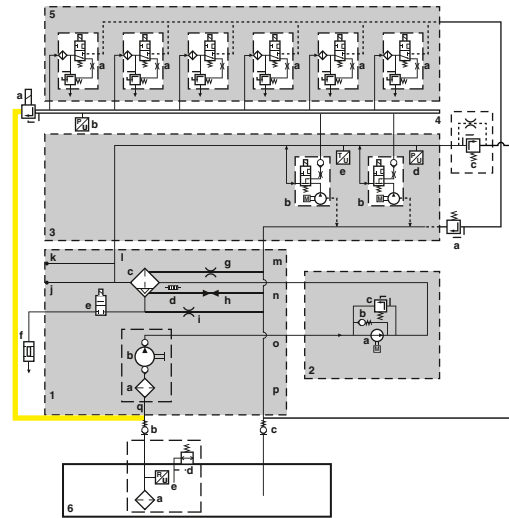
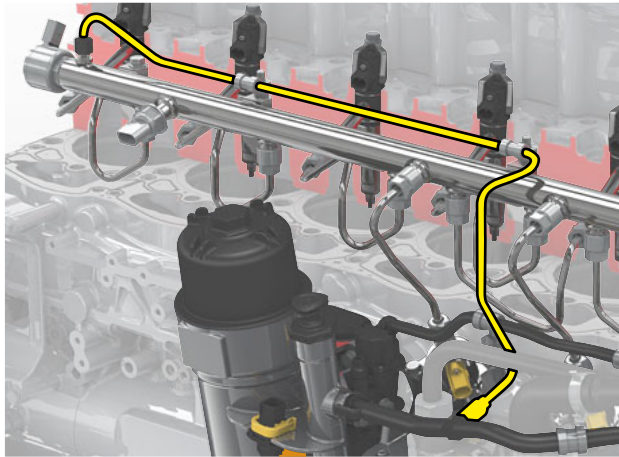

i402035

Leak off from common rail pressure release valve: when a large drop in rail pressure demand is needed, as a result of changes in engine load the common rail pressure release valve (4a) is opened. The leak off fuel is led back to the inlet side of the fuel filtration module (1).

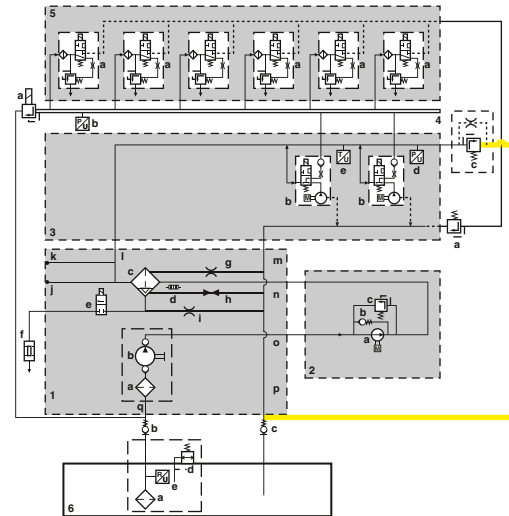
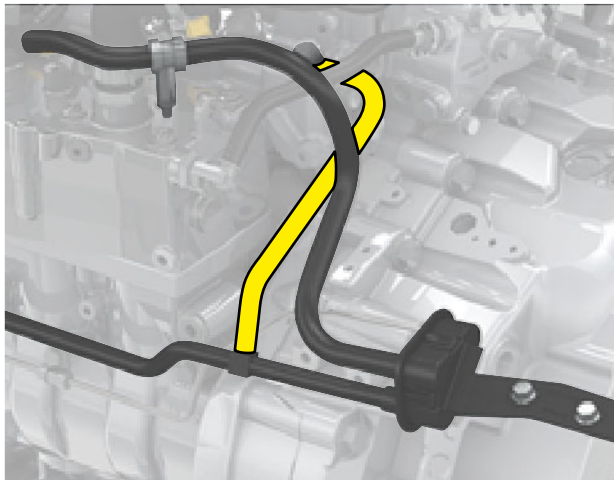

i402037

Leak off from fuel supply gallery: When the pressure in the common rail is high enough, the overhead metering valves of the pump units are not activated and fuel is pumped back into the fuel supply gallery. A non-return pressure valve (3c) regulates the pressure in the fuel supply gallery. The leak off fuel from the pressure valve is led back to the return line to the tank.



# FUEL SYSTEM

## System

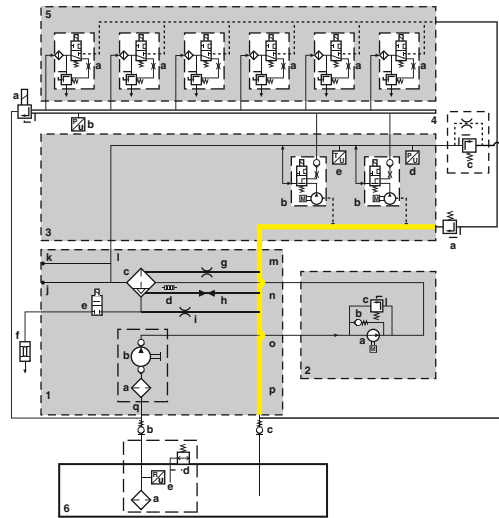
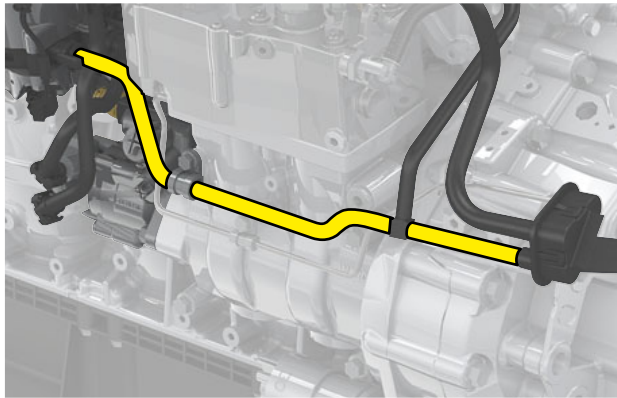

2

The internal leak-off fuel from the pump units is discharged to the return gallery in the cylinder block via a bore. The return gallery is directly connected to the return (1m) in the fuel module. When the cap of the fuel filter is loosened, the fuel is drained from the filter housing back to the tank via two drainholes in the filterbase (1h). These drainholes also prevent the engine from running when there is no filter element installed.

i402038



.....

.....

.....

.....

.....

.....

## **FUEL SYSTEM**

---

System

**2**

### 3. COMPONENTS

#### 3.1 FUEL LIFT PUMP

The low-pressure fuel supply system consists of a fuel filtration module and a fuel lift pump. The fuel lift pump transports the fuel from the tank to the fuel filtration module.

- A Suction side
- B Delivery side
- 1 Pressure release valve

The fuel lift pump is fitted together with the steering pump (tandem pump) at the rear of the air compressor. The crankshaft in the air compressor drives the tandem pump. The fuel lift pump is a gear wheel pump.

A pressure release valve (1) is fitted in the fuel lift pump to protect the low-pressure area of the fuel system against excessive fuel lift pump pressure caused by excessive flow resistance.

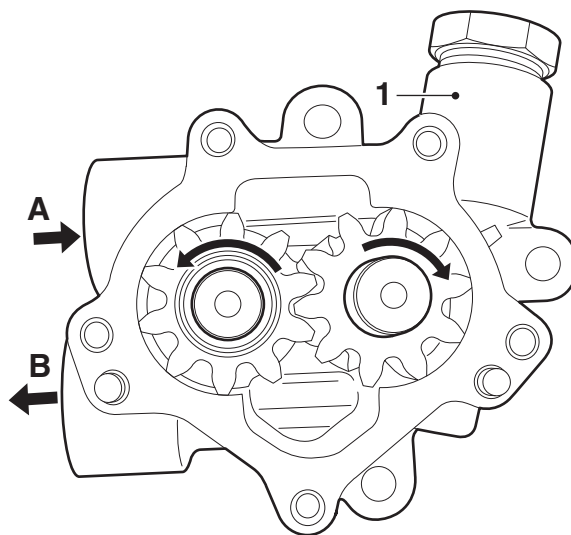

i401400



The drawing shows the schematic of the fuel lift pump (2). What is the code for the pressure release valve in the schematic?

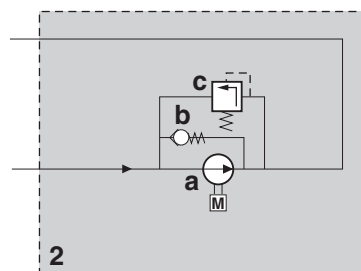

i402021

.....

.....

.....

.....

.....

.....

.....

# FUEL SYSTEM

## Components

### 3.2 FUEL FILTRATION MODULE

The low pressure fuel supply system consists of a fuel filtration module and a fuel lift pump.

2

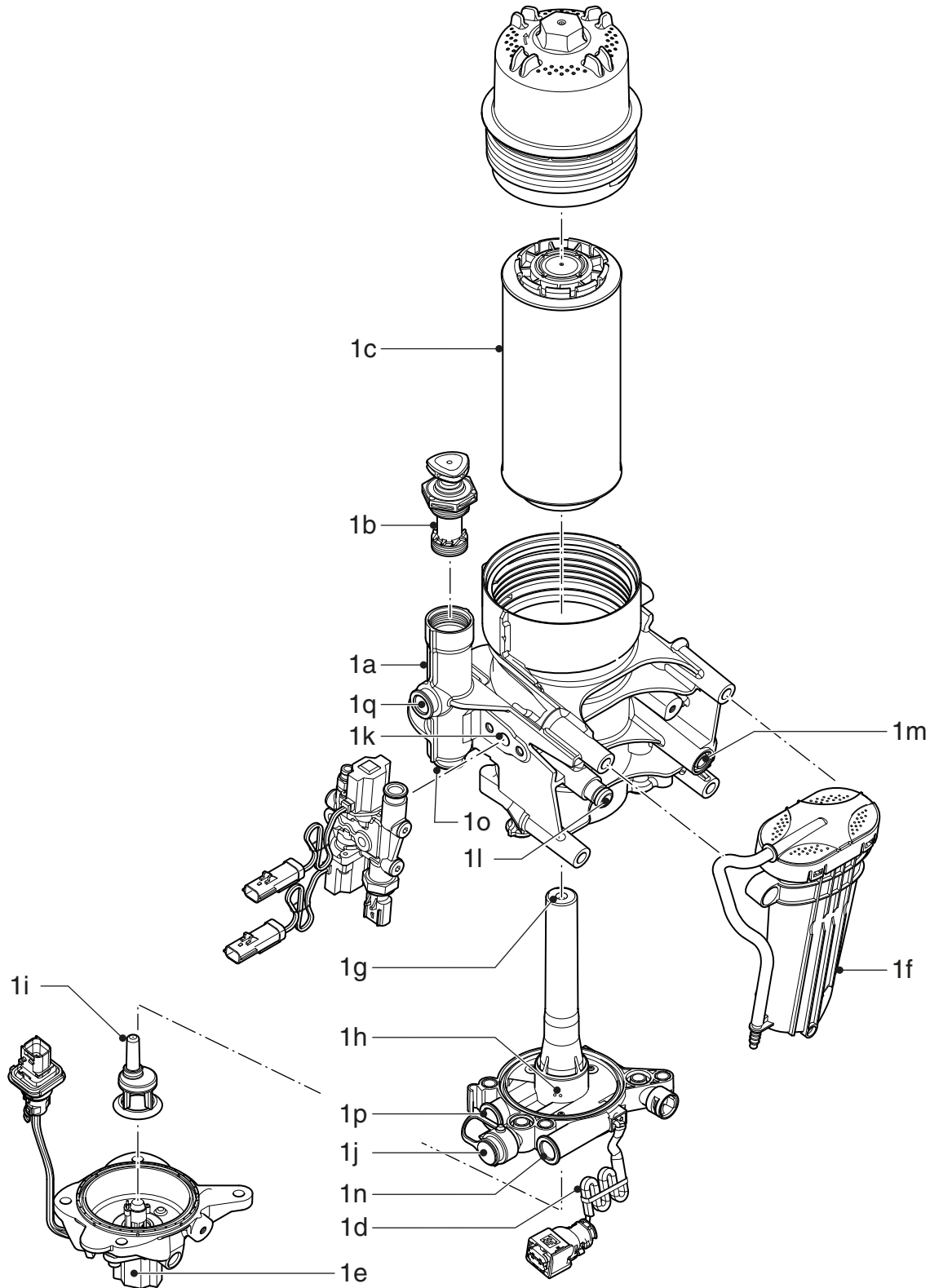

i401927

- 1 Fuel filtration module, L097
- 1a Fuel sieve
- 1b Hand priming pump
- 1c Filter element and water separator
- 1d Fuel heater
- 1e Water drain valve - Water in Fuel Sensor
- 1f Activated Carbon canister
- 1g Deaeration filter (circulation)
- 1h Drain line (filter change)
- 1i Water overflow (redundancy)
- 1j Test connection fuel pressure
- 1k Supply Fuel EAS - Fuel Shut Off Valve
- 1l Fuel connection to gallery
- 1m Fuel return from gallery
- 1n Fuel inlet from lift pump
- 1o Fuel to lift pump
- 1p Fuel return to tank
- 1a Fuel sieve
- 1b Hand pump
- 1c Filter element and water separator
- 1d Fuel heater
- 1e Water drain valve
- 1f Activated Carbon canister

The fuel filtration module has five basic functions:

1. Fuel filter and water separator
2. Water discharge to environment via AC (activated carbon) canister
3. Fuel heater
4. Water separation to AC
5. Hand priming pump

# FUEL SYSTEM

## Components

2

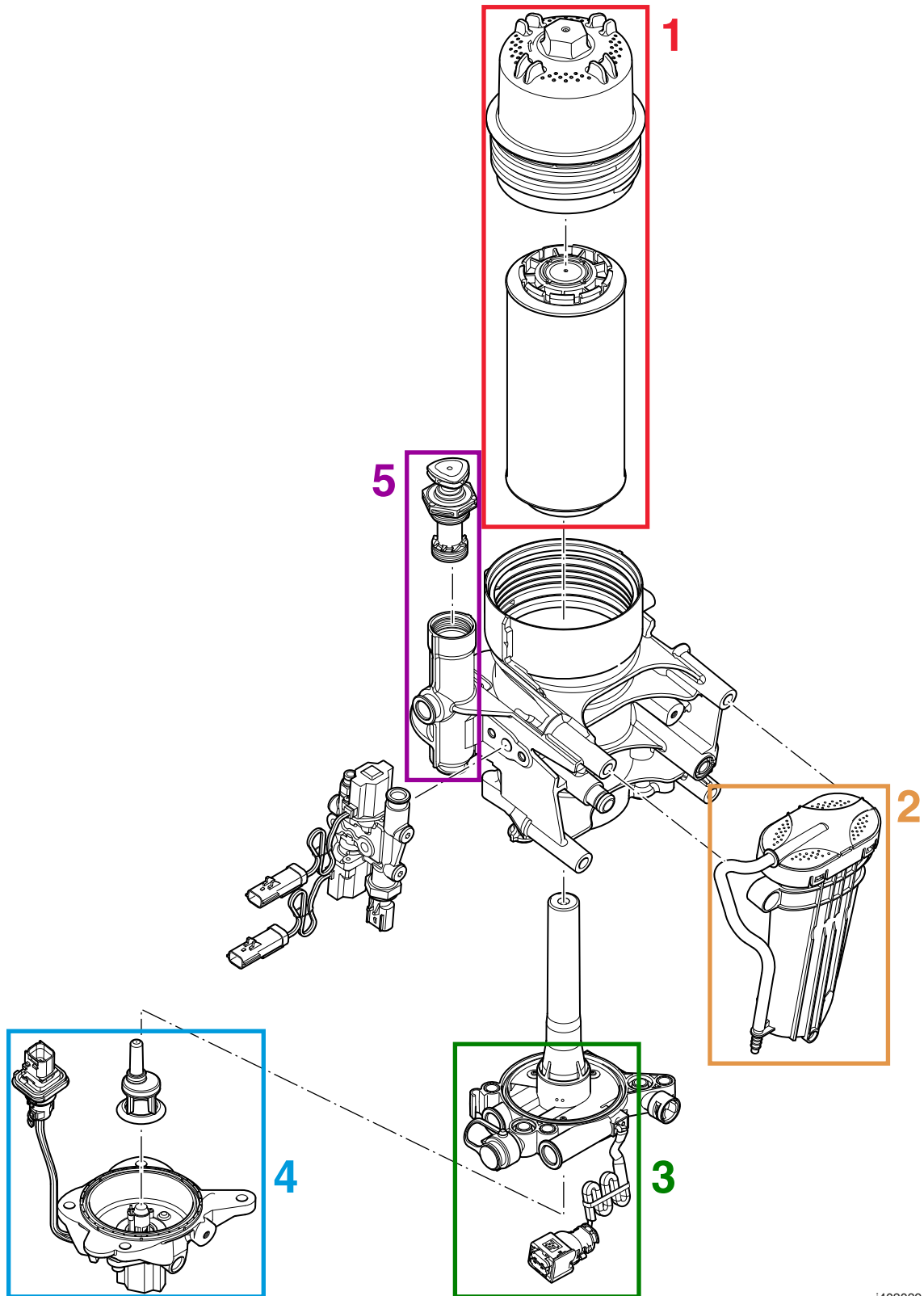

i402039

#### Fuel heater

The fuel from the fuel lift pump enters the module at the blue arrow. All fuel entering the module is passing the fuel heater. Under warm/hot conditions the heater will not function. When the incoming fuel is below  $2\pm 5^{\circ}\text{C}$ , the bi-metal switch will close and the heater will warm up. Since the heater is a self-controlled part, through a fuel immersed bi-metal switch and PTC heater stones, parasitic power consumption will be excluded.

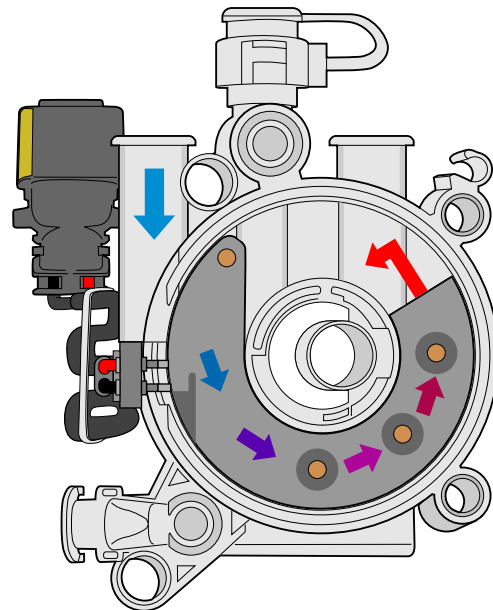

2

i402033

#### Fuel filter and water separator

The main filter element consists of an inner and outer filter element. The outer element is a conventional filter element that has a filtering capacity up to 3 microns. The inner element is an insert with a special hydrophobic coating to separate the water from the fuel. The filter element is patented with No Filter-No Run feature; use of non-original filter will result in strongly reduced engine performance. No filter use will result in non-starting engine. When the filtercover is removed, the filter is lifted and the lower O-ring opens two small drainholes to drain the content of the filtration module back to the tank. The clean fuel is led through an internal bore in the filtration housing and exits directly into the fuel supply gallery in the engine block

# FUEL SYSTEM

## Components

2

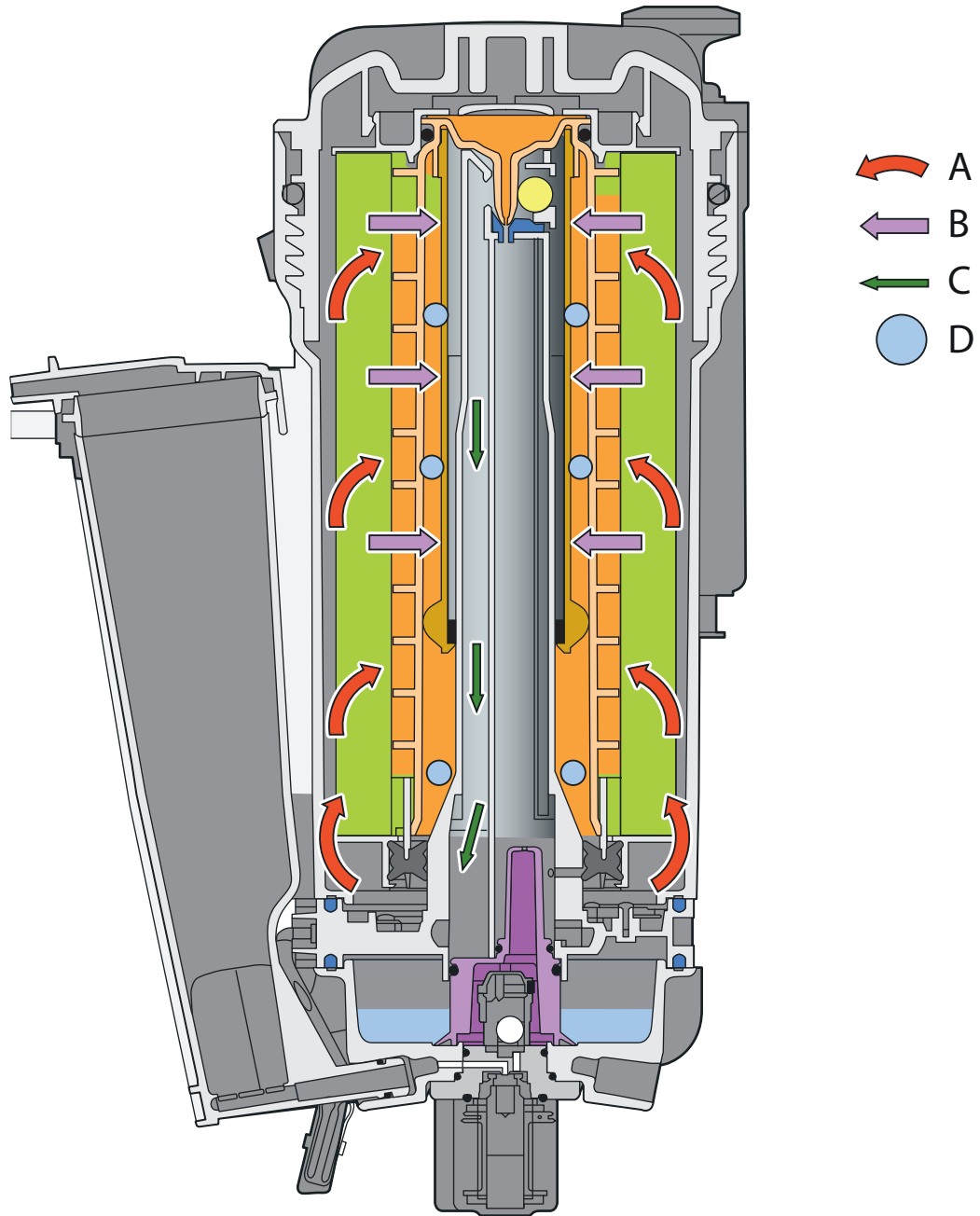

- A Fuel in
- B Fuel through filter element
- C Clean fuel
- D Separated water

i402034

### Water separation to AC

The water that is separated from the fuel by the fuel filter is collected in the water bowl in the lower part of the filterhousing. The water level in the lower bowl is sensed by a Water-In-Fuel sensor. When the separated water level in the bowl is reaching the sensor pins, the voltage reading of the sensor will change and trigger the engine ECU to give a time based actuating signal to the



solenoid of the draining valve. The valve opens the entrance to the Activated Carbon canister (1f) and the water is drained. If the WIF-sensor has a malfunction the voltage reading will be so that the ECU interprets this as a fault and give that info to the driver's info panel. There is a drain hole (1i) to deariate the lower bowl and provide redundant safety in case the valve is malfunctioning.

### Water discharge to environment via AC (activated carbon) canister

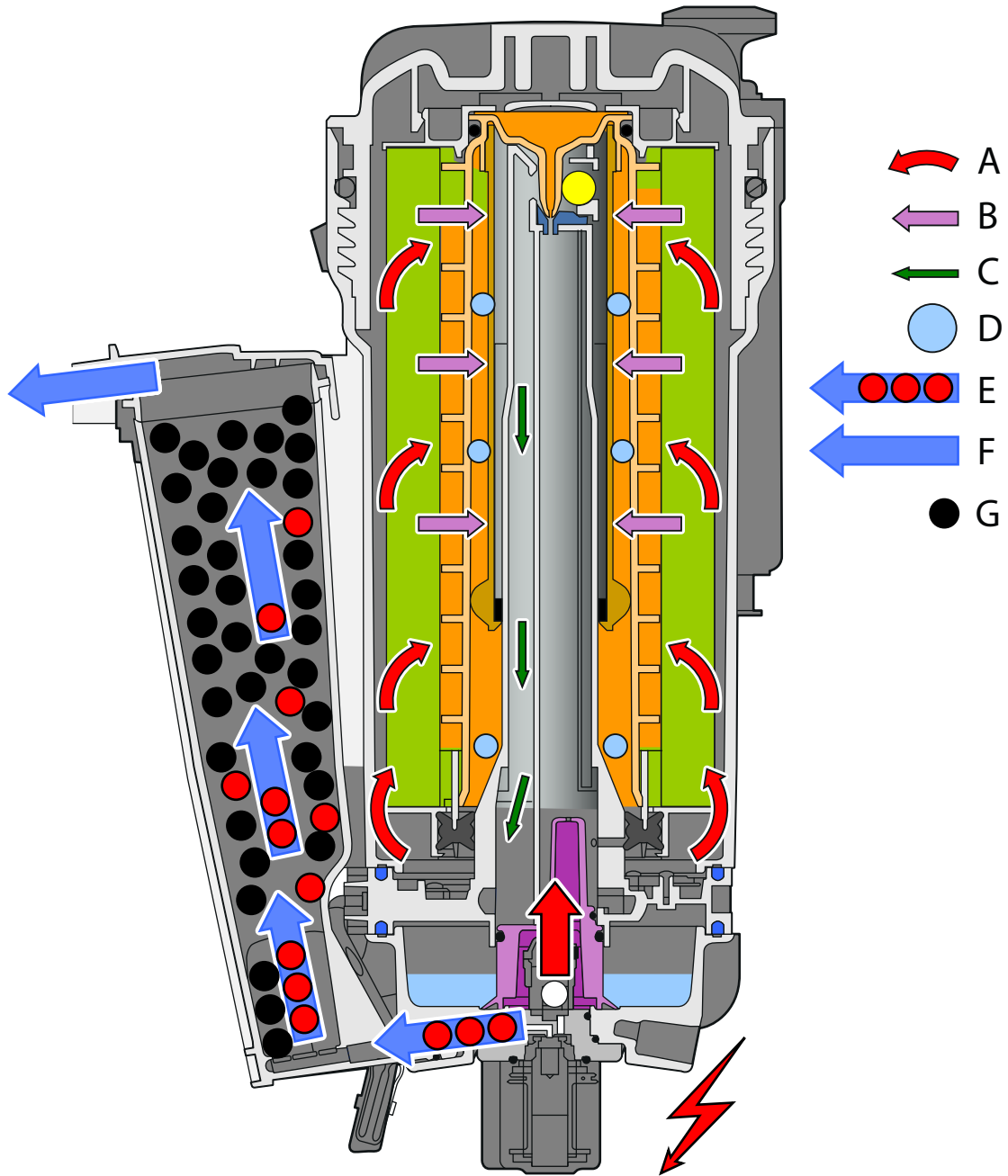

- |   |                             |   |                       |
|---|-----------------------------|---|-----------------------|
| A | Fuel in                     | E | HC-contaminated water |
| B | Fuel through filter element | F | Clean water           |
| C | Clean fuel                  | G | Activated carbon      |
| D | Separated water             |   |                       |

i402062

# FUEL SYSTEM

## Components

The separated water will be directed to an AC-canister where activated carbon reduces the remaining hydrocarbon content in the water to a maximum of 2 ppm. When the AC-canister is completely full the water will be drained to the environment. This water is clean like drinking water. The water-in-fuel disposal needs to be serviced according to the maintenance schematic.

2

### Hand priming pump

- 1q Entrance side
- 1o Exit side

The hand priming pump can be used for bleeding and filling the fuel system. The fuel is entering the fuel module at the hand priming pump. It contains a 300 micron sieve to protect the in- and outlet valves of the pump. This sieve is a fit-for-life part but can be serviced in case of severe contamination. The hand priming pump must be screwed out before it can be operated. From the hand priming pump the fuel flows (1o) to the fuel lift pump. The one-way valve makes sure that the fuel cannot flow back towards the tank during the piston stroke. The pump piston must be screwed in after use.

The fuel is entering the pump housing at connection 1q and is leaving at connection 1o to flow to the fuel lift pump.

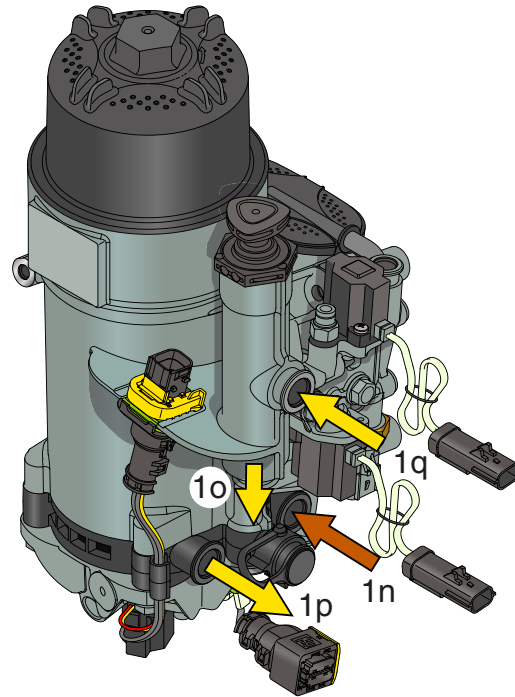

What are the tasks for the hand priming pump?



.....

.....

.....

.....

.....

.....

i401923

**3.3 PUMP UNIT, COMMON RAIL, INJECTOR**

**Pump unit**

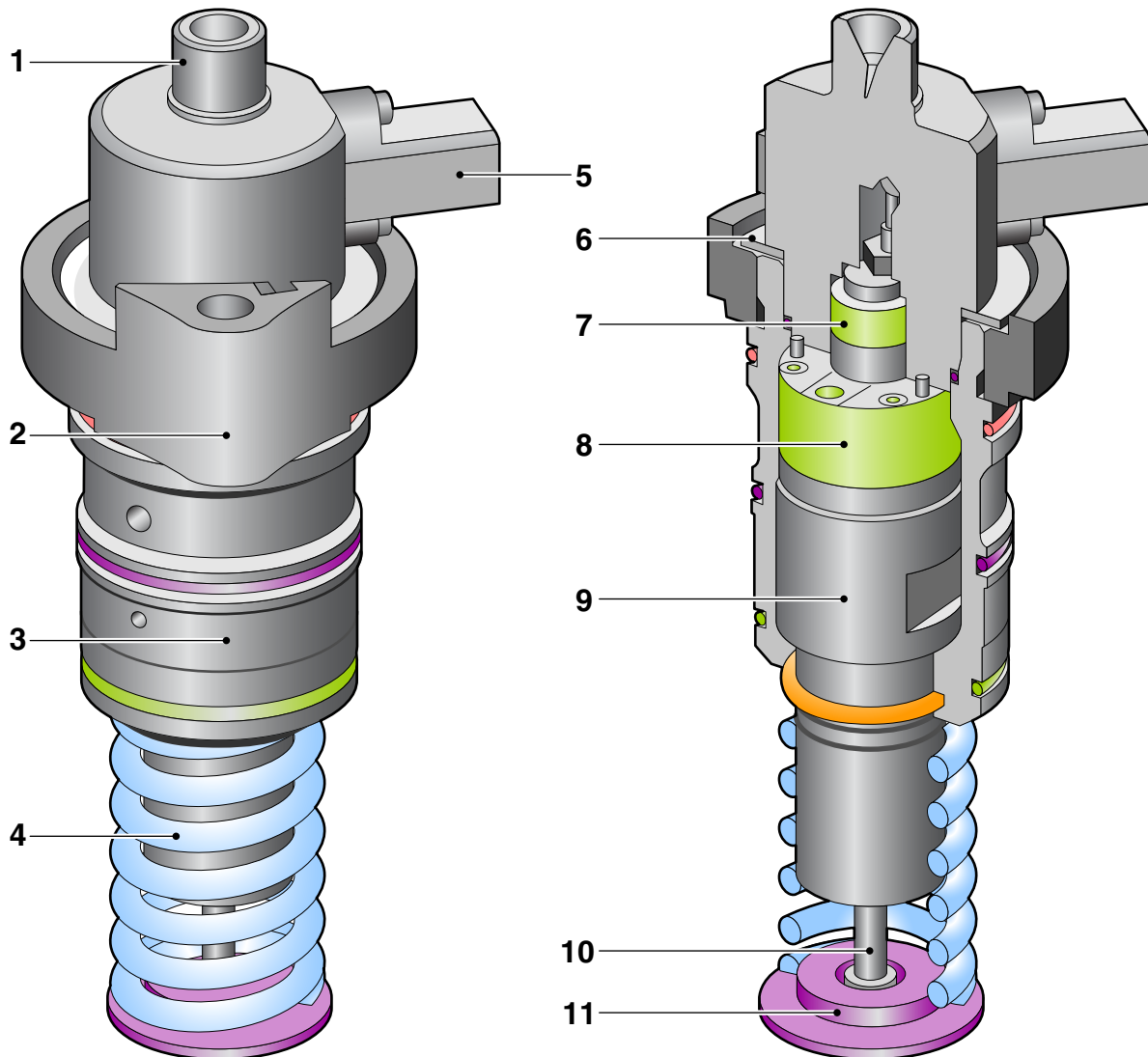

**2**

- 1 High pressure connection
- 2 Clamp
- 3 Capnut
- 4 Plunger return spring
- 5 Header
- 6 Disc spring
- 7 Stator
- 8 Outlet metering valve
- 9 Pumping body
- 10 Plunger
- 11 Thrust pad

i402031

## FUEL SYSTEM

### Components

2

The outlet metering valve (OMV) is integrated in the pump units and is controlled by the ECU. The actual amount of pressure build up to supply the rail is calculated by the ECU depending on several parameters (input signals). The ECU sends an actuation signal to the outlet metering valve at a calculated time before the plunger reaches top dead center (TDC), using the remaining part of the stroke to build up the pressure. When the requested amount of fuel is high, the outlet metering valve will be closed in an early stage, when the requested amount is low the actuation will take place later during the stroke. The outlet metering valve is equipped with a check valve that only has to be actuated for a short period of time and will remain closed until the plunger is moving downwards. The pump units do not require an electronic trim due to the closed loop ECU rail pressure control strategy which adjusts each pump logic as required over the life of the unit.

#### Common rail

The pressurized fuel is sent to the high pressure rail. The rail volume is meant to keep the fuel pressure stable during the injection cycles.

The high pressure system includes a common rail pressure release valve (L094) and a pressure sensor (F854) which are part of the rail assembly.

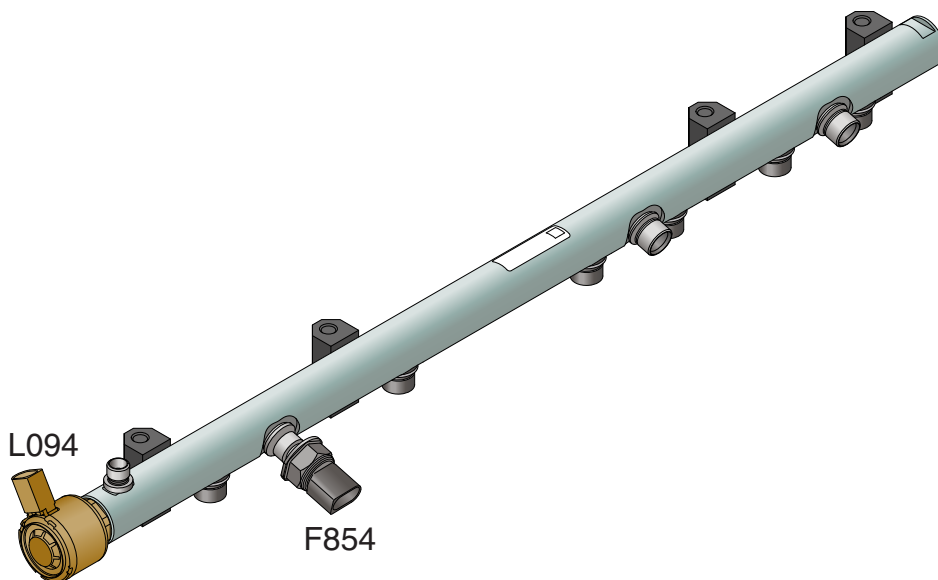

i401930-2

The common rail pressure release valve has the following principal functions:

- To enable rail pressure to be reduced rapidly when required.
- To provide a pressure limiting function in the event of loss of control of the rail pressure due to a failure of, for example, the rail pressure sensor or the electronic control unit.
- To enable open loop rail pressure control for 'limp-home' operation in the event of failure of the High Pressure Sensor.
- To permit a minimum rail pressure sufficient to enable a 'limp-home' function in the event of loss of electrical power to the High Pressure Valve.
- To provide a heating function during cold start by bleeding off a controlled flow of pressurised fuel back to the intake side of the fuel filtration module.

When the common rail pressure release valve (4a) is opened, the fuel is led back to the intake side of the fuel filtration module (1).

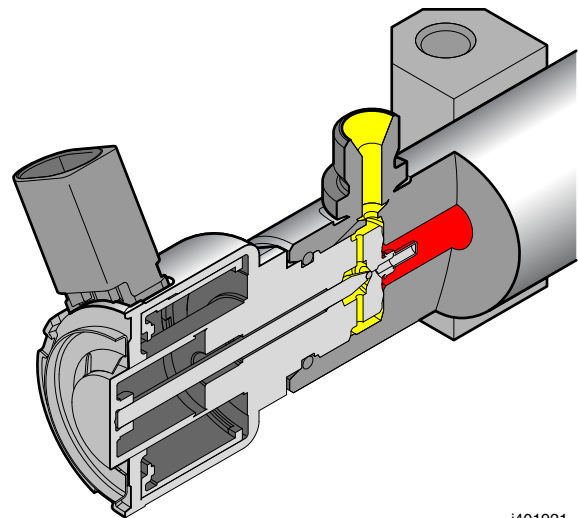

i401921

### Injector

The injectors are mounted in the cylinder head, and are held in place by the injector clamp and accurately orientated to provide a good sealing interface with the injector pipe that is held in place by a tube nut.

# FUEL SYSTEM

## Components

2

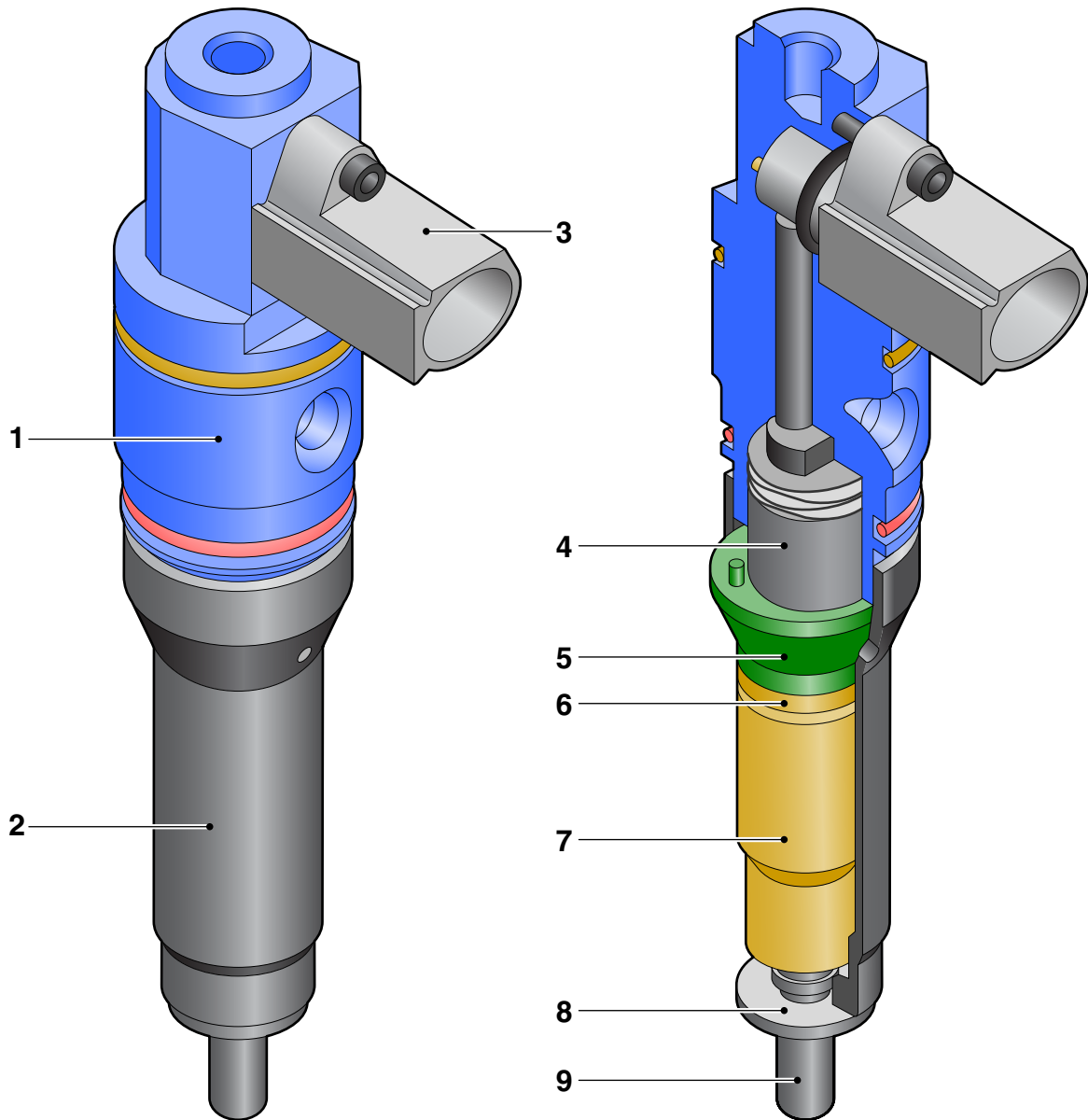

- 1 Injector body
- 2 Capnut
- 3 Header
- 4 Stator
- 5 Nozzle control valve
- 6 Piston guide
- 7 Barrel
- 8 Sealing washer
- 9 Nozzle

i402032

**Camshaft**

The camshaft is equipped with two triangular lobes (C5 - C6) so the pump plungers in the pump units are pumping six strokes over 360° camshaft degrees (720° crankshaft). The stroke of the pump units is configured such that there is one pumping cycle per combustion event to ensure that the pressure at each injector will be nominally the same at the start of the injection sequence. The pump units are phased to the engine crank position.

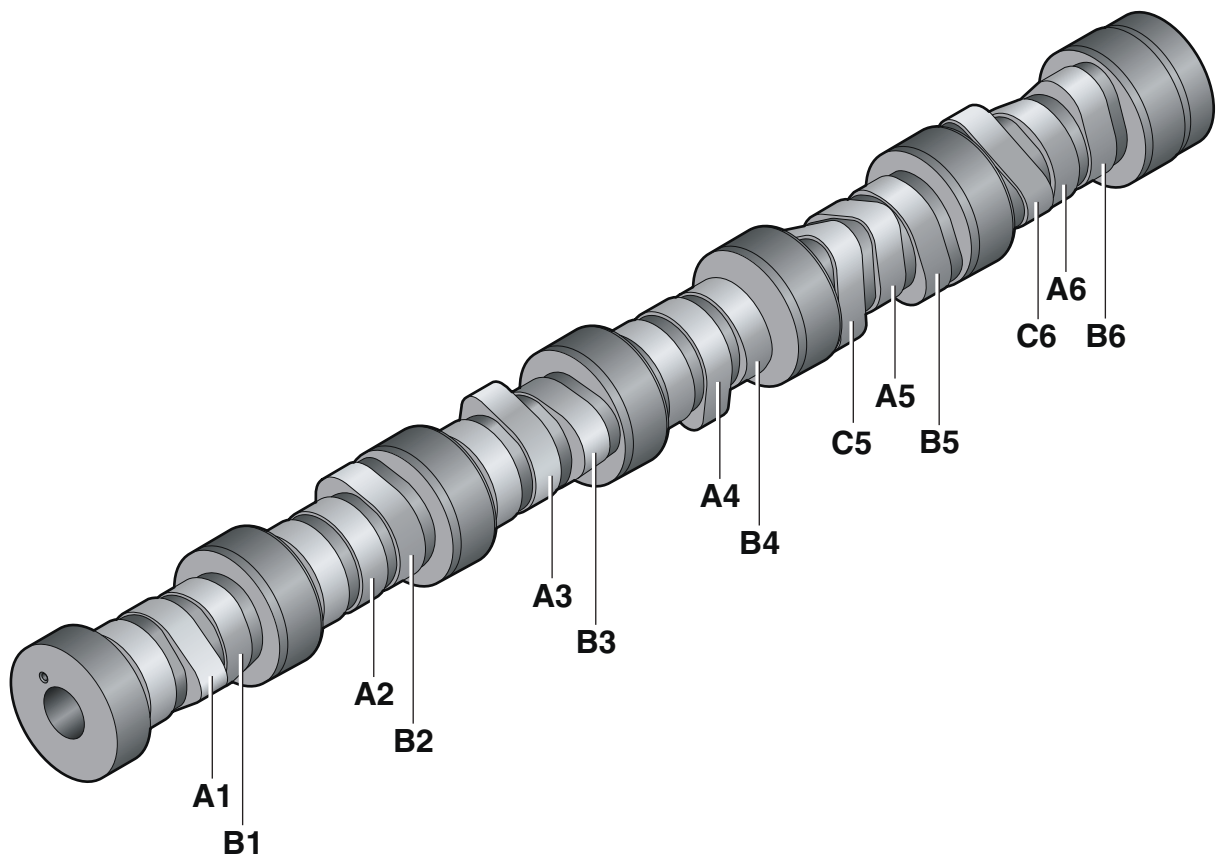

i401968-2

**Injectors - Electronic Trim**

The electronic trim is used to ensure that all injectors run with nominal timing and fuel delivery. This is achieved by adjusting the beginning and end of the electronic drive waveform for each injector to compensate for spread in actuation and deactuation times of the actuator in each injector and to correct for variations in fuelling due to nozzle flow variations.

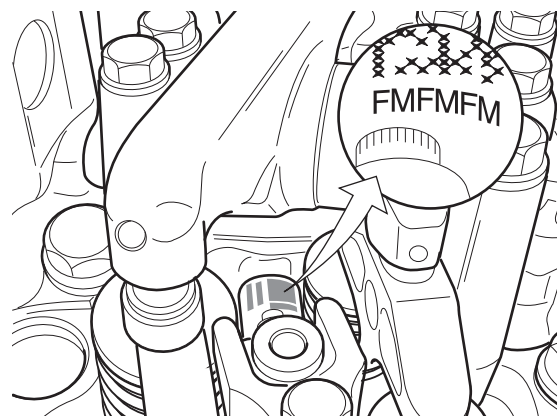

i400772

# FUEL SYSTEM

---

## Components



.....

.....

.....

.....

.....

.....

.....

2



# AIR INLET AND EXHAUST

## Contents

### CONTENTS

	Page	Date
<b>1. INTRODUCTION</b> .....	1-1 .....	201243
1.1 Introduction of air inlet and exhaust system .....	1-1 .....	201243
<b>2. SYSTEM</b> .....	2-1 .....	201243
2.1 System overview: Air inlet and exhaust system. ....	2-1 .....	201243
2.2 System description Air inlet and exhaust system .....	2-4 .....	201243
2.3 MX Engine Brake system description general. ....	2-6 .....	201243
<b>3. COMPONENTS</b> .....	3-1 .....	201243
3.1 Turbo (VTG) .....	3-1 .....	201243
3.2 Exhaust Gas Recirculation (EGR)-valve (L095) .....	3-4 .....	201243
3.3 Exhaust Gas Recirculation (EGR)-cooler .....	3-5 .....	201243
3.4 Back Pressure Valve (L096) .....	3-6 .....	201243
3.5 Fuel Dosing Valve (L124) .....	3-7 .....	201243
3.6 Emission Aftertreatment System (EAS-3) .....	3-8 .....	201243
<b>4. CONTROL FUNCTIONS</b> .....	4-1 .....	201243
4.1 Air Management system .....	4-1 .....	201243



## **AIR INLET AND EXHAUST**

---

### Contents

**3**

**1. INTRODUCTION**

**1.1 INTRODUCTION OF AIR INLET AND EXHAUST SYSTEM**

The air inlet and exhaust system is the collective noun for the engine parts that supply the engine with clean inlet air and discharge of exhaust gas. The inlet air is filtered, compressed, cooled and - under some circumstances- mixed with exhaust gas before it enters the combustion chamber. Exhaust gas is used to drive the turbine, -under some circumstances- cooled and led back to the inlet side. Exhaust gas is also subject to an extensive chemical process to remove the hazardous components, before it enters the atmosphere.

The exhaust system can be used as an engine brake system.



.....

.....

.....

.....

.....

.....

# AIR INLET AND EXHAUST

---

## Introduction

3



## AIR INLET AND EXHAUST

---

### System

- 1 Air inlet
- 2 Turbo with variable geometry (VTG)
- 3 Intercooler
- 4 Inlet manifold
- 5 Exhaust gas manifold
- 6 Exhaust Gas Recirculation (EGR valve)
- 7 Exhaust Gas Recirculation (EGR cooler)
- 8 Venturi
- 9 Back Pressure valve (BPV)
- 10 Fuel Dosing valve
- 11 Emission Aftertreatment System

3

#### **Air inlet**

Fresh air enters the air inlet behind the cabin and passes through the air filter before reaching the compressor side of the turbo.

#### **Turbo with variable geometry (VTG)**

The VTG plays an important role in the total air management system. The operation of the turbine side of the VTG is related to the operation of the EGR-valve and the BPV, different cooperation strategies control the exhaust gas composition that the engine delivers to the EAS. The compressor side of the turbo supplies the air for the combustion process.

#### **Exhaust Gas Recirculation (EGR) valve**

The Exhaust Gas Recirculation is part of the total air management system. The operation of the EGR-valve is related to the operation of the VTG and the BPV, different cooperation strategies control the exhaust gas composition that the engine delivers to the EAS.

#### **Exhaust Gas Recirculation (EGR) cooler**

The Exhaust Gas Recirculation cooler reduces the temperature of the exhaust gas that is led back to the inlet side of the engine.

#### **Back Pressure Valve (BPV)**

The Back Pressure Valve is part of the total air management system. The operation of the BPV is related to the operation of the VTG and the EGR-valve, different cooperation strategies control the exhaust gas composition that the engine delivers to the EAS.

#### **Fuel dosing valve (HC-doser)**

The fuel dosing valve injects fuel into the exhaust pipe before the oxidation catalyst during regeneration to raise the temperature of the exhaust gas.

#### **Crankcase ventilation Module**

The crankcase ventilation Module removes soot and oil out of the crankcase gas stream to a certain amount.

## Emission Aftertreatment System (EAS-3)

The Emission Aftertreatment System converts the harmful components in the exhaust gas to secure that the emissions of the engine comply with legal regulations.



.....

.....

.....

.....

.....

.....

# AIR INLET AND EXHAUST

---

## System

### 2.2 SYSTEM DESCRIPTION AIR INLET AND EXHAUST SYSTEM

#### Overview

The air inlet and exhaust system for the MX-13 can be divided into several subsystems:

- Air inlet system
- Exhaust system
- Emission Aftertreatment System (EAS-3)
- Air management system

#### Exhaust system

The exhaust gases leave the cylinder through two exhaust valves per cylinder and leave the engine via the insulated exhaust gas manifold (5). The exhaust gas flows via the turbine (9) to the EAS-3 (10). The turbo, as part of the air management system, has a sliding nozzle ring to control the flow of the exhaust gases through the turbine. After leaving the DPF unit, the exhaust gases enter the SCR unit. The SCR unit consists of a combination of the Selective Catalytic Reduction catalyst and an Ammonia Oxidation catalyst. The main purpose of the SCR system is to reduce the amount of nitrogen oxide (NOx).

#### Air inlet system

When the turbo charger compresses the inlet air, the temperature of the air increases. To improve combustion, the intercooler cools the boosted air before it reaches the inlet manifold in the cylinder head. As the air exits the intercooler, it is routed to the inlet manifold. The cooled, boosted air mixes under specific circumstances with small amounts of cooled exhaust gas before entering the inlet manifold. The inlet manifold routes the inlet air to each cylinder for combustion. Inlet air enters one side of the cylinder head and exits the other side as exhaust gas. The inlet manifold is integrated in the casting of the cylinder head, each cylinder has two intake valves.

#### Emission Aftertreatment System

The EAS-3 (3th generation of Emission Aftertreatment System) can be divided in two major systems, namely the DPF (Diesel Particulate Filter) system and the SCR (Selective Catalytic Reduction) system. After leaving the engine, the exhaust gases enter the DPF unit. The DPF unit works in combination with a Diesel Oxidation Catalyst and a Diesel Particulate Filter. The main purpose of the DPF system is to reduce the particles in the exhaust gases.



# AIR INLET AND EXHAUST

## System

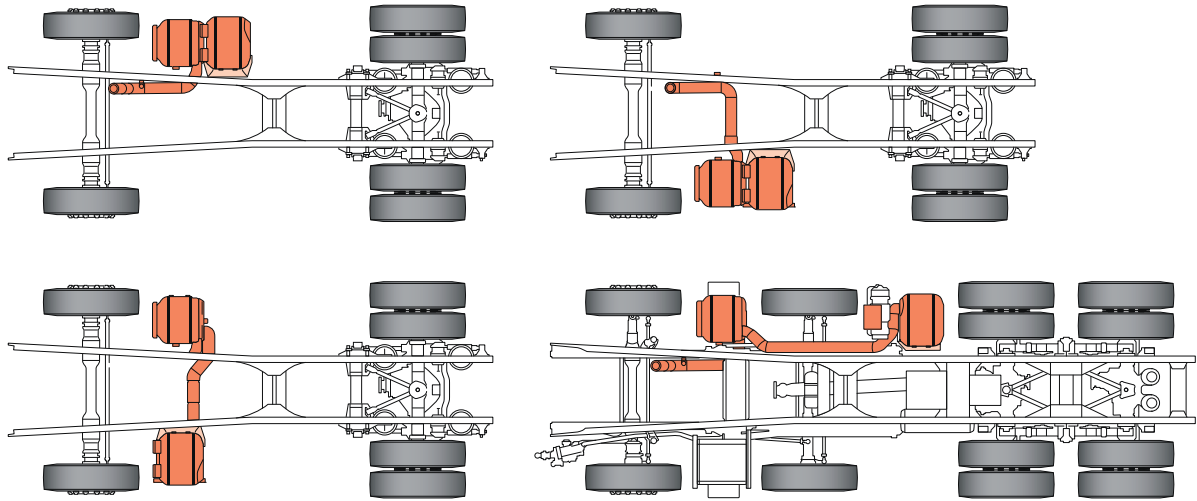

i401989

3

### Air management system

Depending on the engine mode and composition of the exhaust gas the air management system controls the position of the VTG, EGR-valve and Back Pressure Valve. In NOx standard mode, when the NOx level of the exhaust gas towards the EAS can be low, recirculation of exhaust gas is desirable. The EGR valve opens and exhaust gas flows via the EGR cooler through the venturi to the inlet air manifold where it is mixed with the inlet air.

In High efficiency mode, when the NOx level of the exhaust gas towards the EAS can be higher, recirculation of exhaust gas is not needed. The EGR valve closes, sliding nozzle and BPV are opened.

In SCR-heating mode and in DPF-regeneration mode the EGR valve, sliding nozzle from the VTG and the BPV are closed to generate as much heat as possible to burn of the collected soot in the DPF.



.....

.....

.....

.....

.....

.....

## AIR INLET AND EXHAUST

---

### System

### 2.3 MX ENGINE BRAKE SYSTEM DESCRIPTION GENERAL

#### Introduction

MX Engine Brake is available as an option.

This decompression brake delivers the best performance in the higher engine-speed range, indicated in blue on the rev counter.

MX Engine Brake always operates in conjunction with the VTG.

The electronic unit in the engine management system switches MX Engine Brake on and off.

3

#### Engine brake

When activated the engine brake opens the exhaust valves near the top of the compression stroke (at approximately 60° BTDC), to release the highly compressed air through the exhaust system. The compression stroke is used to slow the truck down. Because the exhaust valves open before TDC little energy is returned to the piston, the energy of the truck forward motion is dissipated. Opening is done by the CR cam on the camshaft. Furthermore the exhaust valves are opened shortly after BDC. This is done by the BGR cam on the camshaft. Now exhaust gas enters the cylinder and gives a higher pressure above the piston, which induces further slowing down of the truck. In the non braking mode the solenoid is closed. Oil is pushed in and out of the master slave piston (tappet). In the braking mode the solenoid is opened. By opening the solenoid oil will flow to the actuation piston (LM0 control valve). When the actuation pin is pushed down, the ball in the LM0 control valve is seated, creating an hydraulic lock. Oil is trapped between the master slave piston (tappet), lash setting is no longer hydraulically compensated.

The component consists of 6 engine brake units with actuation system (dedicated cam, solenoids). The illustration is showing a disengaged brake.

## AIR INLET AND EXHAUST

System

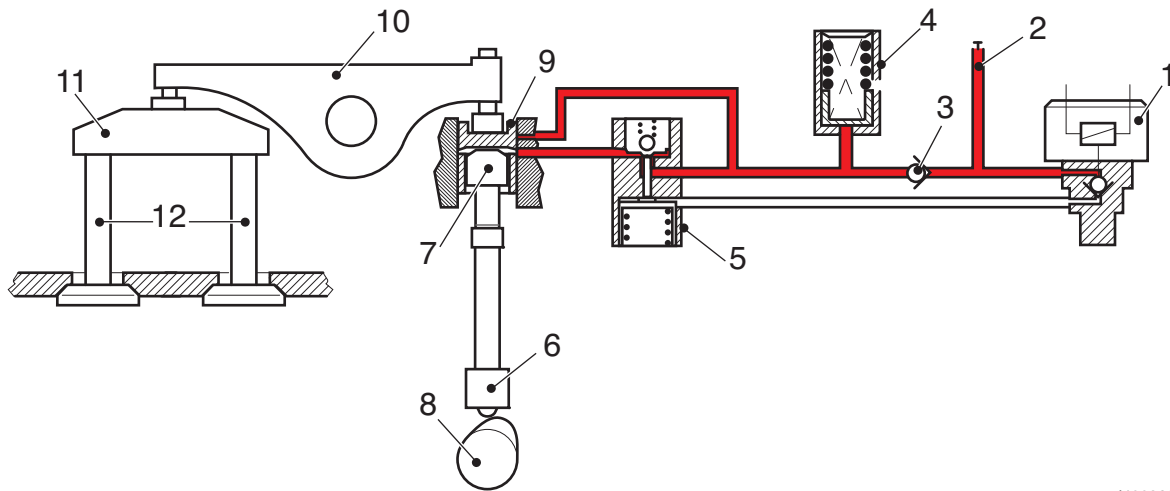

- 1 Solenoid valve
- 2 Cylinder head oil supply
- 3 Non-return valve
- 4 Accumulator
- 5 Control valve
- 6 Exhaust valve push rod
- 7 Piston operating valve
- 8 Camshaft
- 9 Operating valve
- 10 Exhaust valve rocker
- 11 Bridge for exhaust valves
- 12 Exhaust valves

i400862-2

3

### General operation of MX Engine Brake

If the engine brake is activated, both the VTG and MX Engine Brake come into operation. This means that MX Engine Brake always works in conjunction with the VTG. If MX Engine Brake has been activated, no fuel is injected and hence no combustion will take place.

## AIR INLET AND EXHAUST System

### System

#### Position A: Induction stroke

The piston moves down and the cylinder is filled with clean air. Since the exhaust brake is also operated, a high pressure is built up in the exhaust manifold.

By opening the exhaust valves briefly during the induction stroke, additional charge pressure is obtained in the cylinder.

#### Position B: Compression stroke

The piston moves up and compresses the air in the cylinder, creating a braking force. At the end of the compression stroke the exhaust valves are opened. The compressed air can now escape to the exhaust system. Otherwise this compressed air would press the piston down faster.

#### Position C: Power stroke

The piston moves down and the exhaust valves are closed.

#### Position D: Exhaust stroke

The piston moves up, as during a normal exhaust stroke.

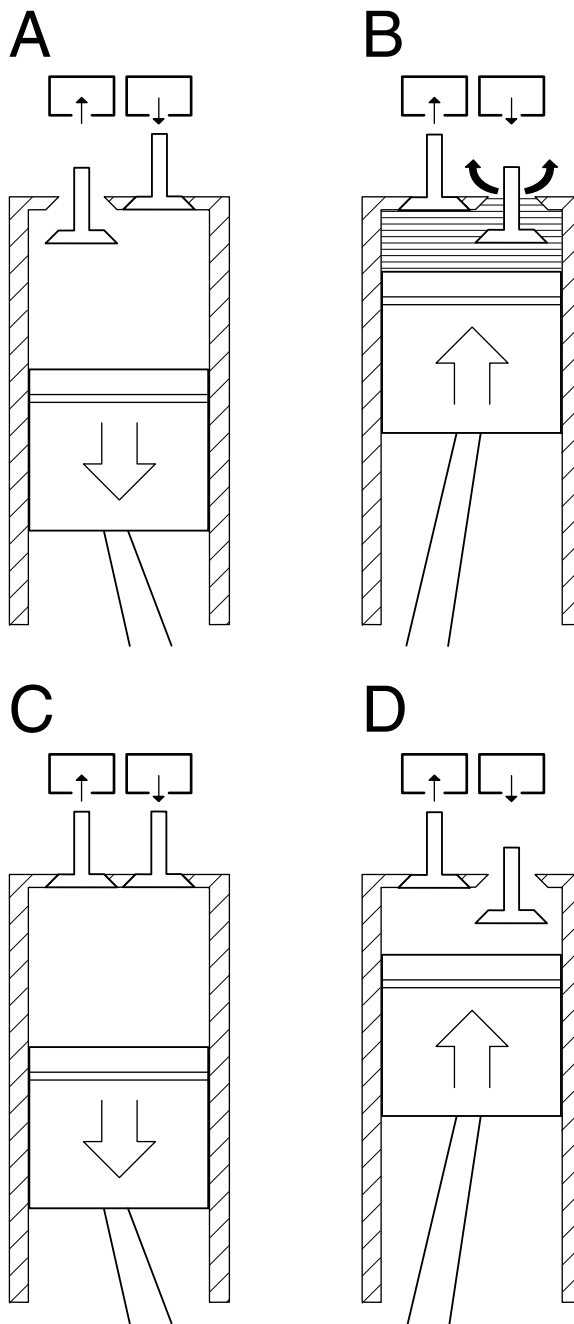

i 400165

### 3. COMPONENTS

#### 3.1 TURBO (VTG)

##### Turbo with variable geometry (VTG)

The position of the sliding nozzle ring determines the amount of exhaust gas that is allowed through (A). When the nozzle ring is fully withdrawn, the opening is maximum and the speed of the exhaust gas to drive the turbine wheel is low. Boost pressure is also low as the compressor wheel rotates at low speed. When the nozzle ring is fully extended, the opening is minimum and the speed of the exhaust gas to drive the turbine wheel is high. Boost pressure is also high as the compressor wheel rotates at high speed. A watercooled, CAN-controlled actuator (B) controls the position of the sliding nozzle ring. The speed sensor monitors the speed of the shaft.

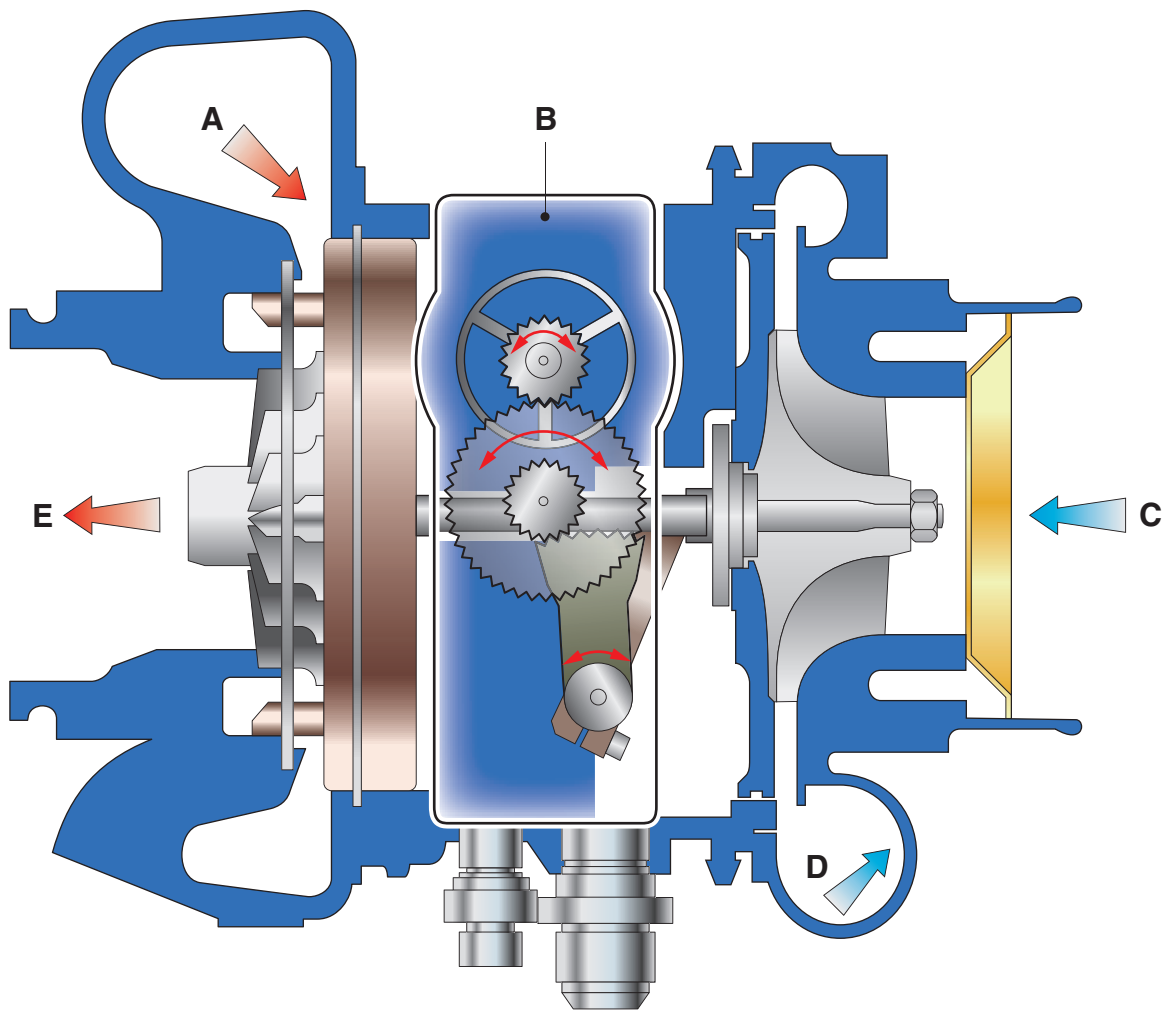

- A Exhaust gas
- B Electronic actuator
- C Inlet air
- D Boost air outlet
- E Exhaust gas outlet

I401938

## AIR INLET AND EXHAUST

### Components

The VTG plays an important role in the total air management system. The operation of the VTG is related to the operation of the EGR-valve and the BPV, different cooperation strategies control the exhaust gas composition that the engine delivers to the EAS.

The VTG uses a turbine stage where the swallowing capacity is automatically varied while the engine is running. This permits boost pressure to be set, providing sufficient energy to drive the compressor at the desired boost level wherever the engine operates. This is achieved by varying the area of a nozzle; a set of guide vanes that control the flow of exhaust gas through the turbine. The vanes slide axially. The sliding nozzle ring alters the aperture through which the exhaust gases flow onto the turbine wheel. This alteration in the geometry of the turbo charger increases the boost as the nozzle is closed down. Reducing the aperture increases exhaust manifold pressure and increases the turbo charger speed. As the nozzle ring opens up, the exhaust pressure reduces and the turbo charger boost decreases.

A watercooled and automatically calibrated electric motor actuator (B) is fitted on the VTG for an accurate operation.

#### Operation

- \* Minimum turbine exit area (1)
- \* Maximum exhaust manifold pressure
- \* Maximum shaft speed
- \* Maximum boost pressure

When maximum boost pressure is needed the actuator moves the nozzle ring to close the aperture to reduce the exhaust gas flow. This results in maximum shaft speed and maximum exhaust manifold pressure. Under specific circumstances this helps to improve the flow of exhaust gas through the EGR.

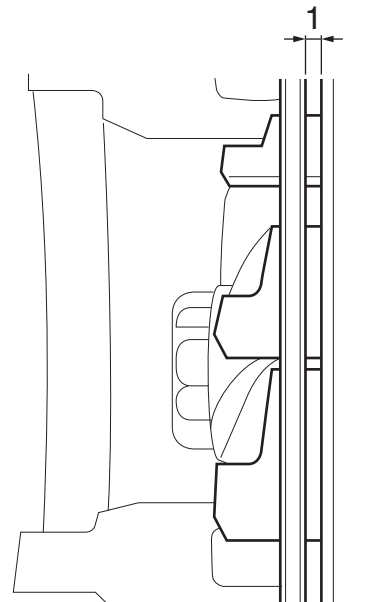

i401658

# AIR INLET AND EXHAUST

## Components

- \* Increasing turbine exit area (1)
- \* Reducing exhaust manifold pressure
- \* Reducing shaft speed
- \* Reducing boost pressure

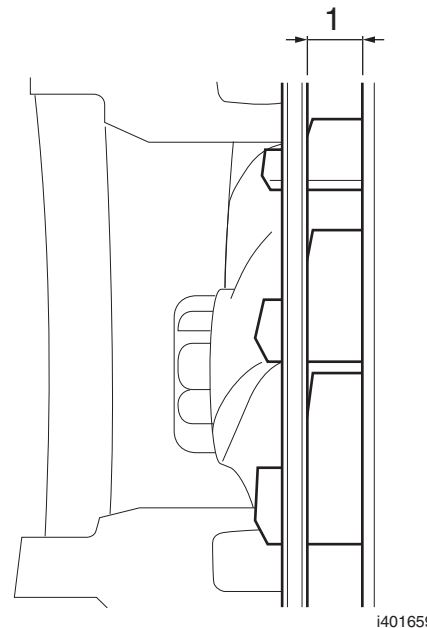

3

- \* Maximum turbine exit area (1)
- \* Minimum exhaust manifold pressure
- \* Minimum shaft speed
- \* Minimum boost pressure

When shaft speed is at a critical (high) level, the actuator moves the nozzle ring to open the aperture to maximise the exhaust gas flow . This results in minimum shaft speed, minimum exhaust manifold pressure and minimum boost pressure. The nozzle ring position is infinitely variable between the end limits.

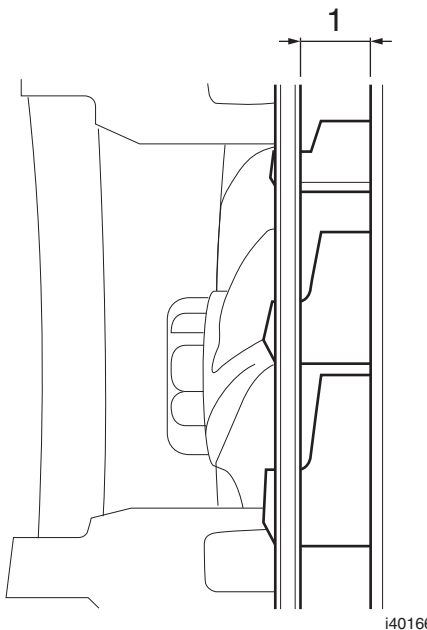

*In how many positions can the nozzle ring be set?  
What is the influence on the shaft speed when the nozzle ring opening is set to maximum open?*



.....

.....

.....

.....

.....

.....

.....

## AIR INLET AND EXHAUST

### Components

#### 3.2 EXHAUST GAS RECIRCULATION (EGR)-VALVE (L095)

- A Flow from exhaust manifold
- B Flow to EGR-cooler
- 1 Actuator with integrated sensors
- 2 Coolant connections
- 3 Valve

When EGR flow is required, the ECU commands the EGR actuator (1) to open the valve (3), allowing exhaust gas to flow through the cooler from A to B. Cooled exhaust then flows into the inlet manifold where it is mixed with inlet air. If additional EGR flow is required, the ECU closes the VTG and BPV accordingly. The EGR-valve is a Smart actuator, so it has integrated software to control the position of the valve, instead of being directly controlled by the ECU. The valve assembly is coolant cooled (2) to increase the durability of the actuator.

The EGR-valve (L095) plays an important role in the total air management system. The operation of the EGR-valve is related to the operation of the VTG and the BPV, different cooperation strategies control the exhaust gas composition that the engine delivers to the EAS. The EGR valve is located between the exhaust manifold at the entrance side of the VTG (A) and the EGR cooler (B). The assembly consists of a motor, valve and a sensor. The CAN controlled motor is used to position the butterfly valve. An internal sensor monitors the motor's position. The valve assembly is coolant cooled (connections 2) to increase the durability of the actuator. When the EGR-valve is opened there is a larger amount of exhaust gas routed back to the inlet manifold (flow from A to B). The fail-safe position of the valve is closed, so no EGR is possible in case of an electrical failure.

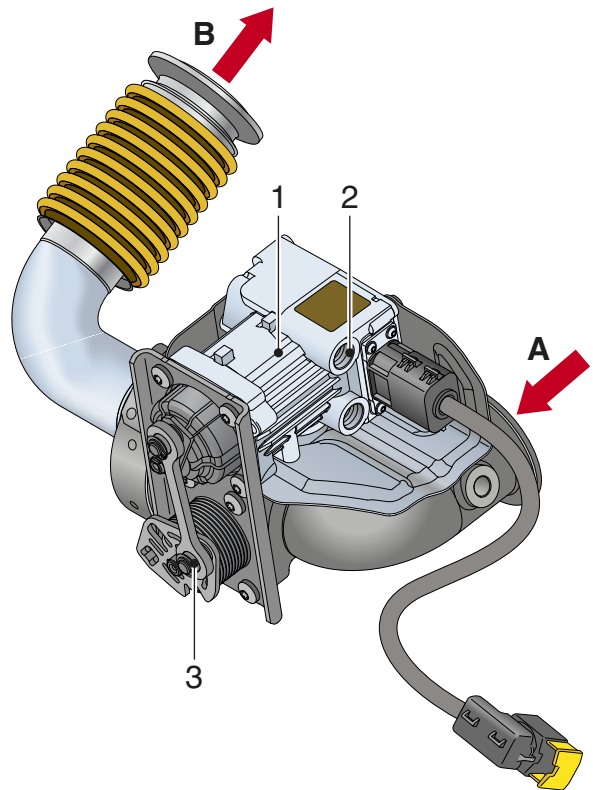

i401970



### 3.3 EXHAUST GAS RECIRCULATION (EGR)-COOLER

#### EGR cooler

- A Exhaust gas EGR-cooler in
- B Exhaust gas EGR-cooler out
- C Coolant EGR cooler in
- D Coolant EGR cooler out

When the EGR valve is opened there is exhaust gas flowing towards the inlet manifold. The exhaust gas passes the EGR valve and flows into the EGR cooler at connection point A. The EGR cooler contains many small pipes for the exhaust gas to flow through. Coolant flows around these pipes to cool the exhaust gas. At connection point B, the cooled exhaust gas flows to the inlet manifold of the engine. Two pressure sensors measure the pressure drop over a venturi to measure the amount of exhaust gas. The coolant for cooling the exhaust gas flows into the EGR cooler at connection point D. The coolant flows out of the EGR cooler at connection point C, directly into the water pump.

Mixing exhaust gas with the inlet air means that there is less oxygen available for the combustion process. The result is that there is less heat produced during the combustion, this has a direct influence on the production of NOx. The level of NOx engine out is an important parameter for the Engine Emission Aftertreatment System (EAS), which is the leading controller for the final tail pipe emissions.

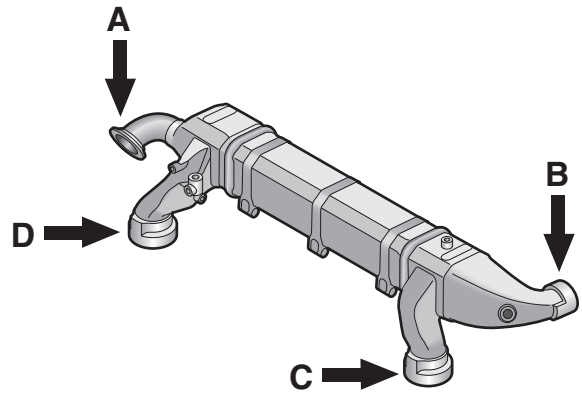

i401958

## AIR INLET AND EXHAUST

### Components

#### 3.4 BACK PRESSURE VALVE (L096)

##### Back Pressure Valve

- 1 Housing
- 2 Valve
- 3 Actuator

The BPV plays an important role in the total air management system. The operation of the BPV is related to the operation of the VTG and the EGR-valve, different cooperation strategies control the exhaust gas composition that the engine delivers to the EAS. The assembly consists of a housing, valve and a motor with integrated sensor. The CAN controlled motor is used to position the butterfly valve. An internal sensor monitors the motor's position. The valve assembly is coolant cooled to increase the durability of the actuator.

The housing of the valve is used as a support for the fuel dosing module, NOx sensor, lambda sensor and temperature sensor. The fail-safe position of the valve is open, so no actuation of the valve is possible in case of an electrical failure.

The BPV has three functions that it can fulfil:

- EAS-control
- Non-MEB braking
- Advanced engine control

EAS-control: When the BPV is closed there is a high back pressure buildup in the exhaust manifold. The result is less flow and -when the HC-doser injects fuel- more heat generated for active and stationary regeneration (aftertreatment).

When the engine is not equipped with a MEB the BPV can be closed to block the exhaust flow so the engine uses the compression force to slow down the engine. The BPV supports the VTG in this, as the sliding nozzle ring of the VTG is also capable of limiting the exhaust gas flow.

The BPV also has a task in engine control, by closing the valve the pressure drop over the VTG can be reduced rapidly to prevent the VTG from overspeeding.

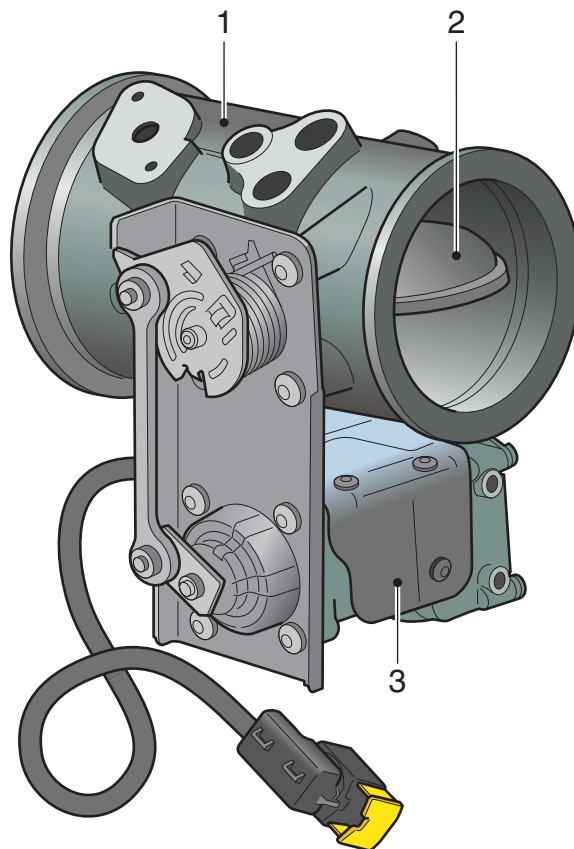

i401975

## AIR INLET AND EXHAUST

### Components

#### 3.5 FUEL DOSING VALVE (L124)

- 1 Coolant exit
- 2 Fuel supply
- 3 Coolant entrance

The fuel dosing valve (L124) is mounted after the Back Pressure Valve. During regeneration, the fuel dosing valve injects fuel into the exhaust pipe before the oxidation catalyst. This is to raise the temperature of the exhaust gas after the oxidation catalyst to the temperature at which the soot is 'burned' in the DPF by the oxygen in the exhaust gases. The fuel dosing valve is activated with a duty cycle so the amount of injected fuel can be regulated to keep the DPF at the correct temperature. The fuel is supplied at connection (2). When the engine is running, engine coolant enters the fuel dosing valve at connection (3). The coolant flows through the fuel dosing valve and cools it down; it leaves the fuel dosing valve at connection (1). From here it flows back to the engine.

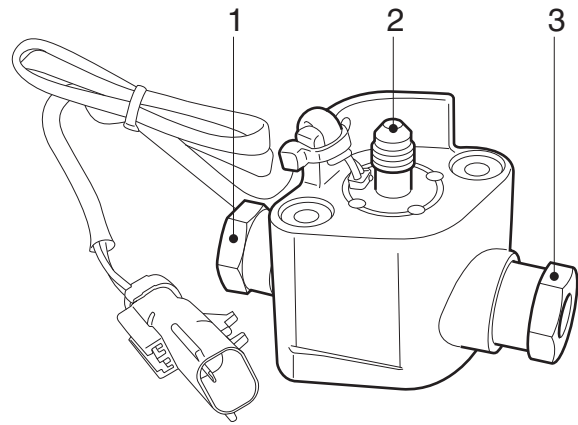

i401680

## AIR INLET AND EXHAUST

---

### Components

#### 3.6 EMISSION AFTERTREATMENT SYSTEM (EAS-3)



**WARNING! Smoke on first regeneration:**  
*During the first regeneration of the Euro 6 Emission Aftertreatment System the system will generate smoke. Whilst the smoke is not considered harmful sufficient precaution should be taken to minimise exposure by making sure that the first regeneration is not carried out in a confined/enclosed space. Furthermore, inhalation of the smoke must be avoided if possible.*

**Background:** *Within the aftertreatment system an insulating material is used to prevent the exterior of the system from reaching high temperatures. The insulation uses an organic binder for packaging purposes which is known to smolder once it reaches >300°C. The combustion of this binder does not affect the performance of the aftertreatment system. During normal vehicle operation the maximum temperature reached is below the temperature required for the binder to begin smoldering. During periodic intervals the aftertreatment system will begin a regeneration cycle. It is during these regeneration cycles that the temperature of the aftertreatment system will increase to the point where the insulation binder will begin to smolder releasing smoke from the aftertreatment system. The binder is typically consumed within the first full regeneration cycle after which time no further smoke should be seen from the system, however, it is possible that the smoke may continue in subsequent regenerations until the binder is fully consumed. Analysis of the smoke shows trace quantities of Carbon monoxide (CO).*

## AIR INLET AND EXHAUST

### Components

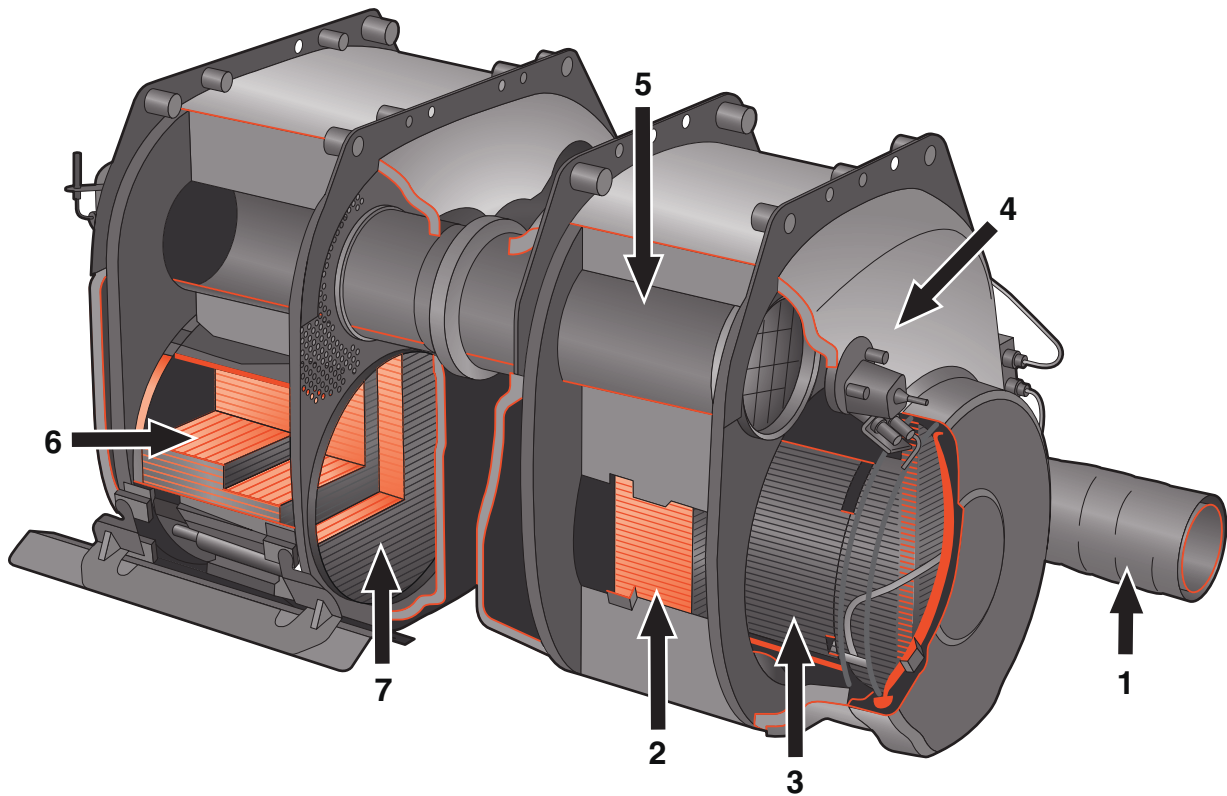

- 1 Exhaust gas from engine
- 2 DOC (Diesel Oxidation Catalyst)
- 3 DPF (Diesel Particulate Filter)
- 4 Diesel Exhaust Fluid (DEF) doser
- 5 Decomposition pipe
- 6 Selective Catalytic Reduction (SCR)
- 7 Ammonia Oxidation Catalyst (AMOX)

i402104

### Operational background

In theory, when fuel is burned, there is a chemical reaction taking place. Under the influence of heat, Hydrocarbons ( $C_xH_y$ ) break up and connect to Oxygen (O) resulting in Carbon-dioxide ( $CO_2$ ) and water ( $H_2O$ ). In practice though, this process is disturbed by a number of hard to control conditions such as excessive heat or lack of oxygen. As a result, internal combustion engines emit four major types of emissions:

- Oxides of Nitrogen (NOX)
- Particulate Matter (PM)
- Hydrocarbons (HC)
- Carbon Monoxide (CO)

NOX are highly reactive gases that form when fuel is burned at high temperatures with excess air. It is primarily composed of nitric oxide (NO) and nitrogen dioxide ( $NO_2$ ).

PM is a mixture of solids and liquids that might include soot from incomplete combustion.

HC's are the result of unburned fuel and lubricating oil.

# AIR INLET AND EXHAUST

## Components

CO, Carbon Monoxide is an odourless and colourless gas that is the result of incomplete combustion, primarily from a lack of sufficient oxygen in the engine cylinder.

### Component overview

The first compartment of an EAS system consists of a DOC (Diesel Oxidation Catalyst), a ceramic open structure coated with catalytic material. The DOC is combined with a DPF (Diesel Particulate Filter), a so called wall-flow filter that traps soot (PM or carbon, C).

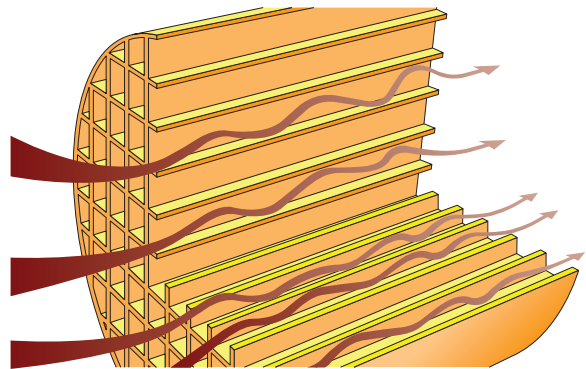

i401987

After DOC and DPF, the third step is Selective Catalytic Reduction (SCR). The SCR is positioned in the second compartment of the EAS. In this process, NOx in the exhaust gases is converted into harmless water and inert nitrogen, both present in the atmosphere. Before the exhaust gas enters the SCR compartment, it is dosed with Diesel Exhaust Fluid (DEF), 32.5% CO(NH2)2 + 67.5 % H2O. The commercial name for this mixed product of urea and water is AdBlue. The last step is the Ammonia Oxidation Catalyst (AMOX), to reduce the unreacted ammonia from the exhaust gas before it enters the atmosphere.

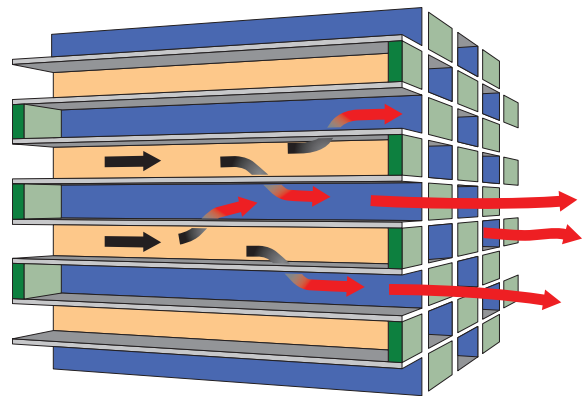

i401988

3



.....

.....

.....

.....

.....

.....

### 4. CONTROL FUNCTIONS

#### 4.1 AIR MANAGEMENT SYSTEM

##### EGR system

The EGR (Exhaust Gas Recirculation) system is used to reduce the NOx emission in the exhaust gas. EGR recirculates a part of the engine's exhaust gas back into the intake manifold. NOx is mainly produced at high combustion temperature and pressure. The intake air mainly consists of N<sub>2</sub> and O<sub>2</sub>. Under high pressure and high temperature N<sub>2</sub> and O<sub>2</sub> are oxidated to NOx. By letting less air and more exhaust gas into the combustion chamber, less N<sub>2</sub> oxidates into NOx. In addition to this, exhaust gas is an inert gas that does not participate in the combustion process. This results in a lower combustion temperature and lower NOx emissions.

During engine operation, EGR flow is controlled by the ECU according to multiple inputs including:

- engine load
- coolant temperature
- manifold temperature
- boost pressure
- oxygen level in the exhaust

## AIR INLET AND EXHAUST

### Control functions

#### Back Pressure Valve (BPV)

Positioned immediately after the turbo, and in close cooperation with it, is the Back Pressure Valve. The assembly consists of a housing (1) with a valve (2), controlled by an actuator with integrated sensors (3). The CAN controlled actuator is used to position the butterfly valve. An internal sensor monitors the position of the valve. The actuator is coolant cooled to increase the durability, a temperature sensor is integrated in the housing. The BPV is a smart actuator, so it has integrated software to control the position of the valve, instead of being controlled by the ECU.

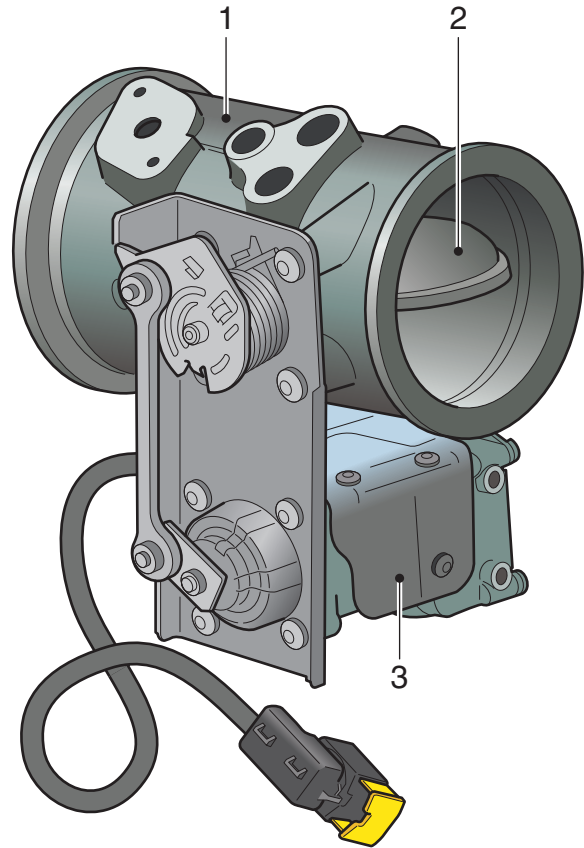

3

i401975



# COOLING SYSTEM

## Contents

### CONTENTS

	Page	Date
<b>1. INTRODUCTION</b> .....	1-1 .....	201243
1.1 Introduction cooling system .....	1-1 .....	201243
<b>2. SYSTEM</b> .....	2-1 .....	201243
2.1 Overview components cooling system .....	2-1 .....	201243
2.2 System description cooling system .....	2-3 .....	201243
<b>3. COMPONENTS</b> .....	3-1 .....	201243
3.1 Coolant pump .....	3-1 .....	201243
3.2 Radiator .....	3-3 .....	201243
3.3 Coolant filter .....	3-4 .....	201243
3.4 Electronically controlled fan clutch .....	3-5 .....	201243
3.5 Component Description: Oil cooler .....	3-6 .....	201243
3.6 Component Description: EGR Cooler .....	3-7 .....	201243
<b>4. FUNCTIONS</b> .....	4-1 .....	201243
4.1 Electronically controlled fan clutch .....	4-1 .....	201243
4.2 Cold Start speed control .....	4-7 .....	201243

# COOLING SYSTEM

---

## Contents

4

# 1. INTRODUCTION

## 1.1 INTRODUCTION COOLING SYSTEM

The goal of the cooling system is to keep the temperature of the coolant between predefined lower and upper limits, under all possible environmental circumstances. Engine coolant is used to transfer the heat (a result of friction and combustion) from the engine to the environment. Coolant is also used as a heatsource to warm up the interior of the cabin and parts of the Emission Aftertreatment System.



*What are the coolant properties for the coolant that has to be used in the MX-13 engine?*



.....

.....

.....

.....

.....

.....

# COOLING SYSTEM

---

## Introduction

4

**2. SYSTEM**

**2.1 OVERVIEW COMPONENTS COOLING SYSTEM**

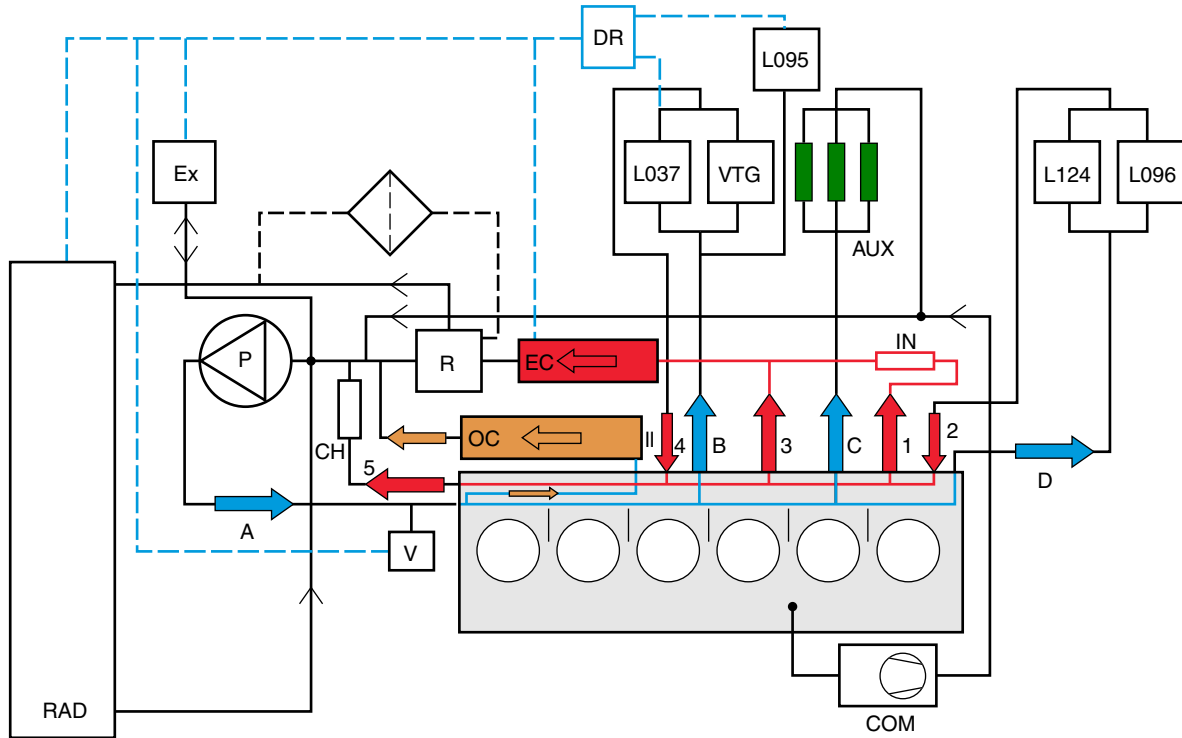

- I -II Coolant flow from coolant pump to oil cooler
- A Coolant flow from coolant pump
- B Coolant flow to VTG
- C Coolant flow to auxiliaries
- D Coolant flow to fuel dosing valve (L124) & BPV module (L096)
- 1 Coolant flow to interarder (plugged for Non-intarder)
- 2 Coolant flow from fuel dosing valve (L124) & BPV module (L096)
- 3 Coolant flow to EGR-cooler (plugged for intarder)
- 4 Coolant flow from VTG
- 5 Coolant flow to heater
- L124 Fuel Dosing Valve
- L096 BPV module
- L095 EGR valve module
- L037 Rotary speed actuator (VTG)
- R Regulators (Thermostats) in coolant pump
- P Coolant pump
- OC Oil cooler
- CH Heater
- EC EGR-cooler
- AUX Auxilairy components

- IN Interarder
- V Verturi
- Ex Expansion tank
- COM Compressor
- RAD Radiator
- DR De-aeriation

i401981

# COOLING SYSTEM

---

System



.....

.....

.....

.....

.....

.....

4

**2.2 SYSTEM DESCRIPTION COOLING SYSTEM**

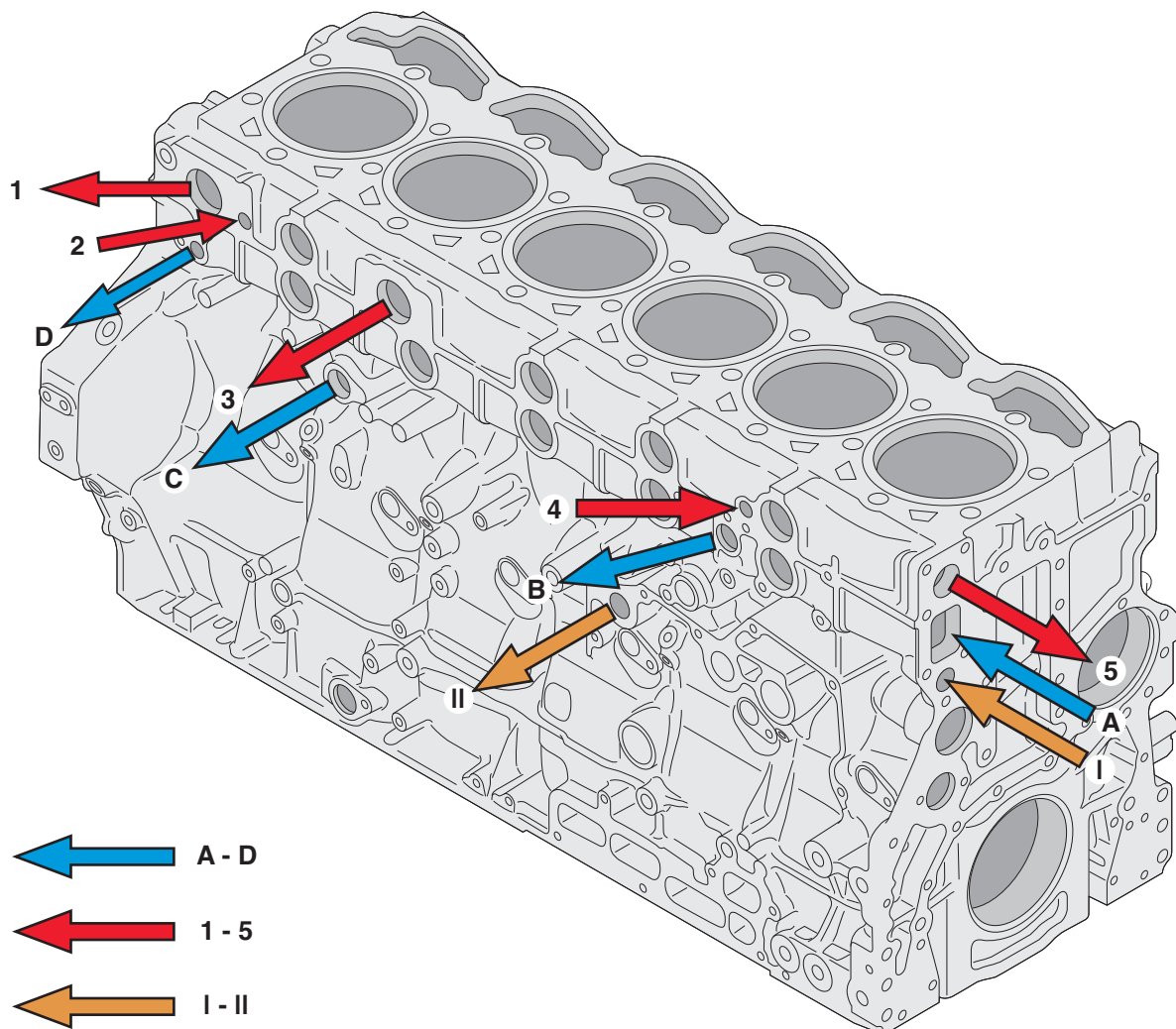

i401980

I - II	Coolant flow from coolant pump to oil cooler
A	Coolant flow from coolant pump
B	Coolant flow to VTG
C	Coolant flow to auxiliaries
D	Coolant flow to fuel dosing valve (L124) & BPV module (L096)
1	Coolant flow to intarder (plugged for Non-intarder)
2	Coolant flow from fuel dosing valve (L124) & BPV module (L096)
3	Coolant flow to EGR cooler (plugged for intarder)
4	Coolant flow from VTG
5	Coolant flow to cabin heater

The coolant flow starts with the rotation of the coolant pump. The coolant flows from the pump into the low temp gallery (A).

# COOLING SYSTEM

## System

Approximately 17% of the coolant flows from A to the oil cooler (I). From the oil cooler, the coolant returns to the inlet side of the coolant pump. The venturi (V) measuring the EGR flow is also coolant cooled and connected to the coolant pump with a separate line.

Inside the engine the coolant cools the cylinder liners and the cylinder head, also some of the coolant flows through the air compressor. From the air compressor, the coolant returns to the intake of the pump through a pipe.

There are three connection points at the low temperature gallery of the engine (B, C, D). From connection B the coolant flows to the VTG and VTG actuator, with a separate line to the EGR-valve actuator. The return from VTG and actuator flows back to the block connection 4, a part of the coolant from EGR valve actuator and VTG actuator flows to the expansion tank, this also deaerates the system.

From connection C the coolant flows to the auxiliaries like gearbox cooler, heater for Urea Dosing System, EAS and back to the suction side of the coolant pump via the return line coming from the compressor.

From connection D the coolant flows to the fuel dosing module and the BPV-actuator and returns to the high temperature gallery in the block via connection 2.

From the high temperature gallery in the engine block, the coolant flow depends of the application of an intarder. When an intarder is used, connection 1 is used and the coolant flows through the intarder and EGR cooler to enter the thermostathouse. Connection 3 is plugged in that case.

The coolant flows through the EGR cooler directly from connection 3 when there is no intarder applied, connection 1 is plugged in that situation. The high temperature gallery is also the supply for the cabin heater system, connection 5 passes through the coolant pump and returning to the inlet side of the pump.

4



.....  
.....  
.....  
.....  
.....  
.....



**3. COMPONENTS**

**3.1 COOLANT PUMP**

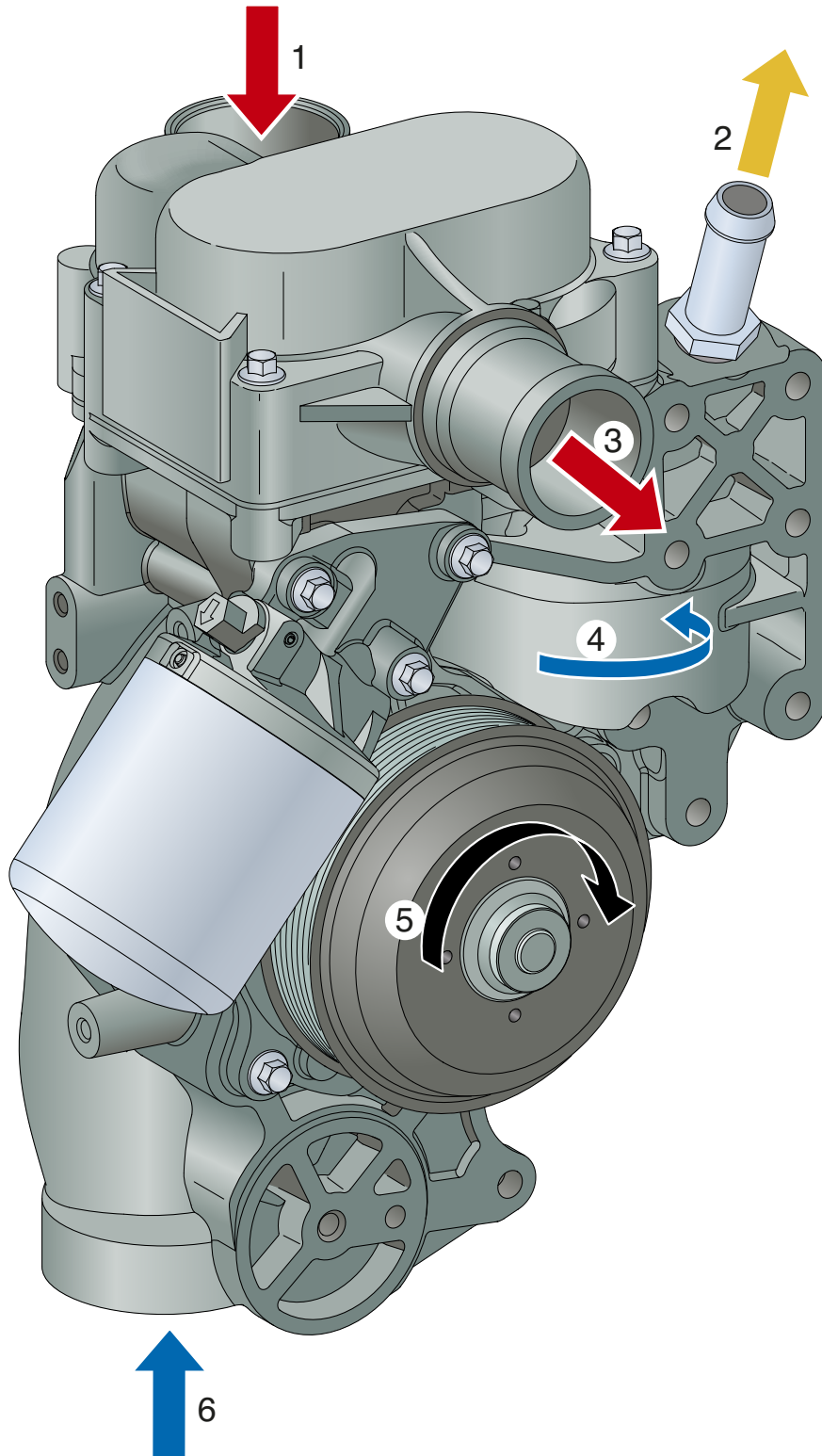

i401941

## COOLING SYSTEM

### Components

- 1 Coolant from EGR-cooler
- 2 Coolant from engine return gallery to cabin heater \* ! no connection to pump just passing through!
- 3 Coolant to radiator (hot)
- 4 Coolant to engine block and oil cooler
- 5 Rotation direction of the pump
- 6 Coolant from radiator

### Coolant Pump

The coolant pump is located at the right-front side of the engine and driven by a single belt from the crankshaft pulley (5). The pump has two integrated thermostats to reduce the pressure difference over the pump. The coolant entering the pump comes from the EGR-cooler (full flow) (1) and flows, depending on the temperature, through the radiator (3 » 6) or directly into the engine block (4). The pump is equipped with a sensor that detects a stalled pump, the sensor is located at the V-belt tensioner.

The coolant entering the engine block is divided between the main coolant gallery in the block and the coolant supply to the oil cooler. The coolant returning from the oil cooler enters at the rear side of the pump. The supply for the cabin heater is connected at (2) but this part of the pump has no internal connection to the coolant pump. The return gallery in the engine block feeds the cabin heater.

The coolant pump is equipped with two thermostats (1 and 2) to provide sufficient flow over the pump.

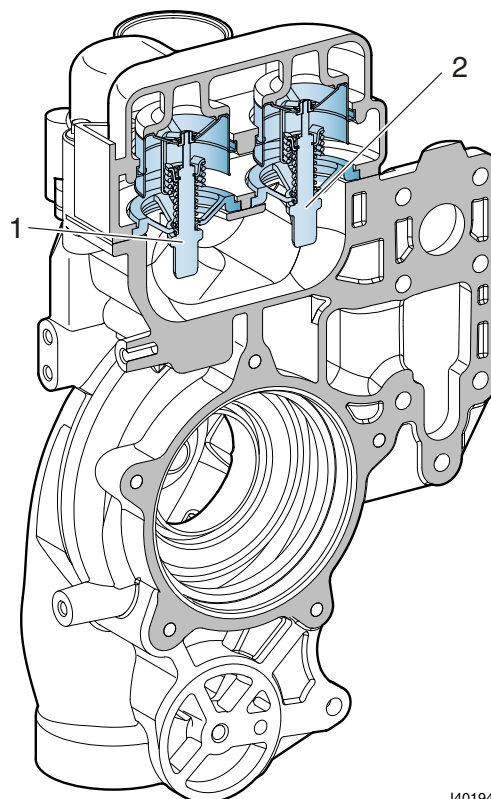

I401942-2

### 3.2 RADIATOR

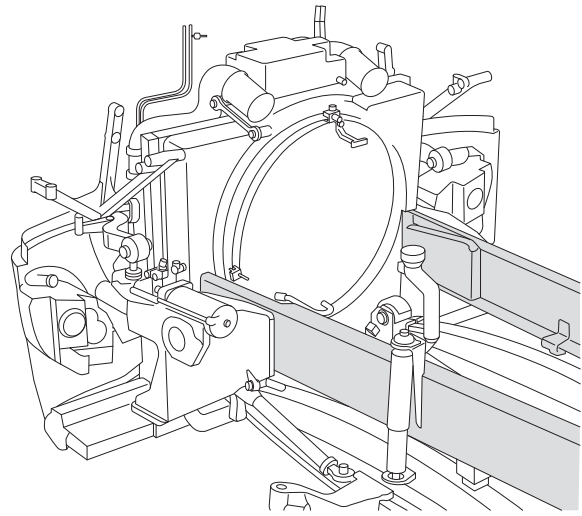

i402027

4

#### **Radiator**

The radiator is the heat exchanger to transfer the heat from the coolant to the environment.

The coolant transported to the radiator enters the radiator at the top and leaves it at the bottom. The coolant flows from back to the coolant pump via the coolant return pipe.

Function: cool down coolant to keep several components at operating temperature

Input: hot coolant, ambient air

Output: cold coolant, hot air

## COOLING SYSTEM

### Components

#### 3.3 COOLANT FILTER

A coolant filter may be included parallel to the cooling system. The coolant filter is attached to the coolant pump housing. The task of the coolant filter is to filter the coolant to prevent cavitation.

The coolant is cleaned in the coolant filter. If the pressure in the coolant filter is too great due to pollution, the filter element is pressed downwards against the spring pressure. The coolant then passes through the coolant filter unfiltered.

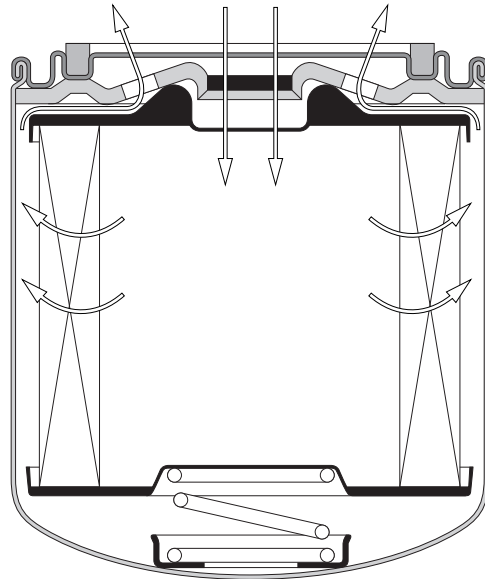

M201439

### 3.4 ELECTRONICALLY CONTROLLED FAN CLUTCH

#### Overview

The electronically controlled fan clutch provides sufficient air flow through the radiator in all possible circumstances, even in situations when the truck does not have driving speed. An electronically controlled fan clutch (B335) is used for accurate control of the fan speed.

- 1 Stator
- 2 Valve
- 3 Rotor
- 4 Coil
- 5 Drive shaft
- 6 Supply chamber
- 7 Working area

The electronically controlled fan clutch checks and controls the fan speed to make sure that the flow of cooling air through the cooling system is sufficient to keep the coolant temperature and/or inlet air temperature within certain limits.

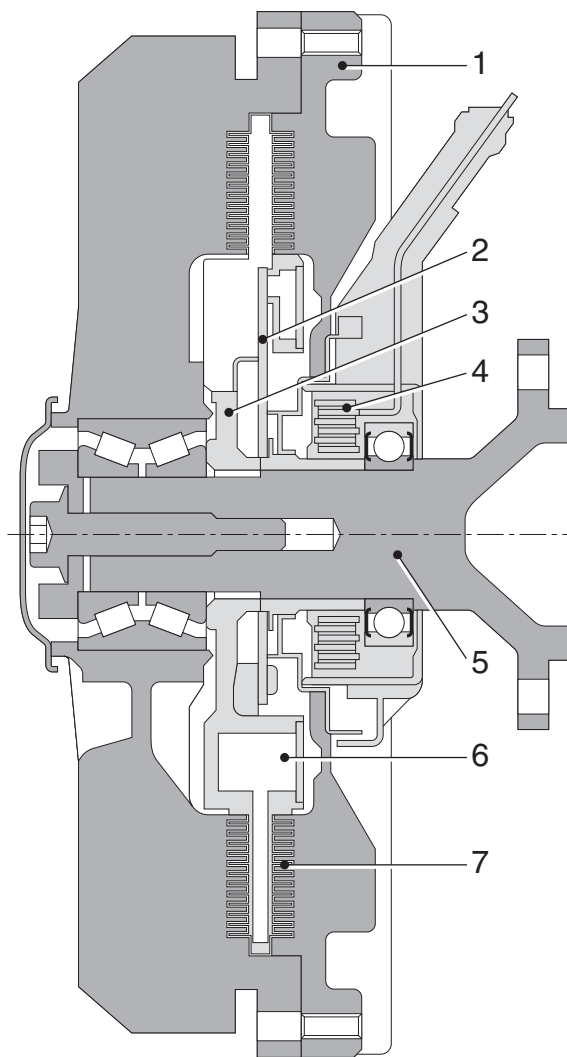

i401951

.....

.....

.....

.....

.....

.....

## COOLING SYSTEM

### Components

#### 3.5 COMPONENT DESCRIPTION: OIL COOLER

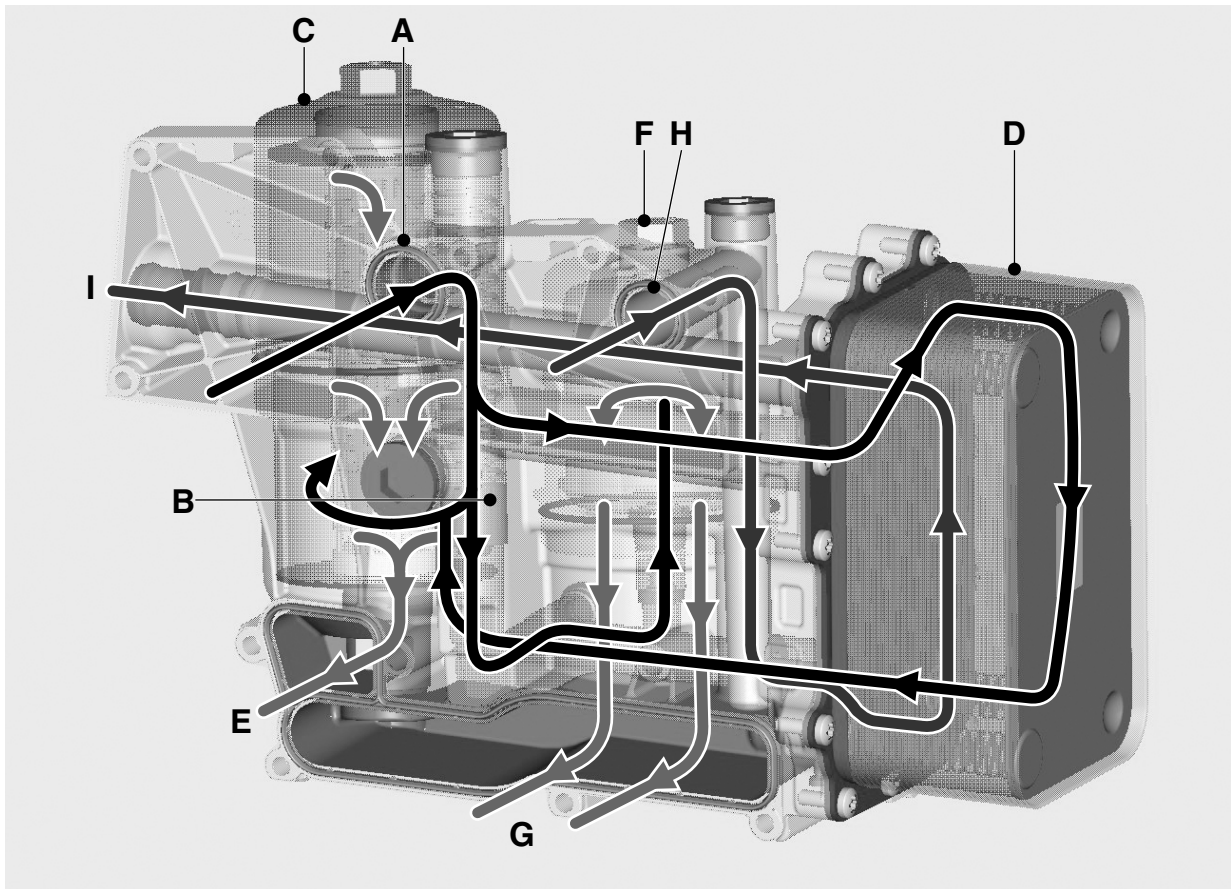

M201442

- A Oil from engine block to oil cooler
- D Oil cooler
- E Cooled and filtered oil to engine block
- H Coolant from engine block to oil cooler
- I coolant from oil cooler to coolant pump

#### Oil Cooler

The oil cooler is part of the cooling system, the heat from the oil is transferred to the coolant in the oil cooler. The oil cooler is the heat exchanger to transfer the heat from the oil to the coolant. The oil cooler is located in the oil module at the right side of the engine. The coolant which is to cool the lubricating oil enters the oil module via opening (H). From here the coolant flows through the oil cooler (D) and leaves the oil module via the channel (I) to the coolant pump.

Function: cool down oil to keep several components at operating temperature

Input: cold coolant, hot oil

Output: hot coolant, cold oil

**3.6 COMPONENT DESCRIPTION: EGR COOLER**

- A Exhaust gas in
- B Exhaust gas out
- C Coolant from EGR cooler to water pump
- D Coolant in

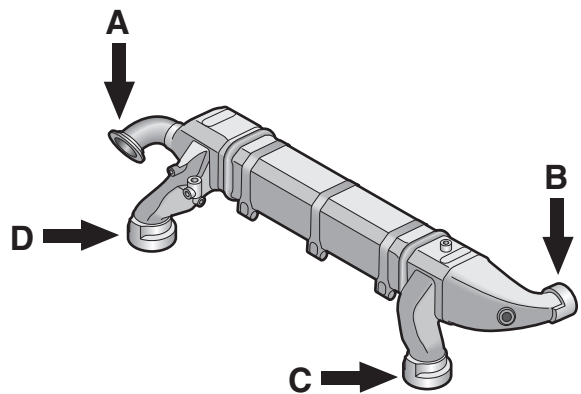

i401958

**EGR Cooler**

The EGR cooler is part of the cooling system, the heat from the exhaust gas is transferred to the coolant in the EGR cooler. The EGR cooler is the heat exchanger to transfer the heat from the exhaust to the coolant. The EGR cooler is located at the right side of the engine. The coolant which is used to cool the exhaust gas enters the oil module via opening (D). From here the coolant flows through the EGR cooler and leaves via connection (C) to the coolant pump.

Function: cool down exhaust gas that is routed back to the intake side of the engine to reduce temperature of air entering the engine.

Input: cold coolant, hot exhasut gas

Output: hot coolant, cold exhaust gas to mix with intake air

## **COOLING SYSTEM**

---

### Components

**4**



## 4. FUNCTIONS

### 4.1 ELECTRONICALLY CONTROLLED FAN CLUTCH

#### Operation speed control

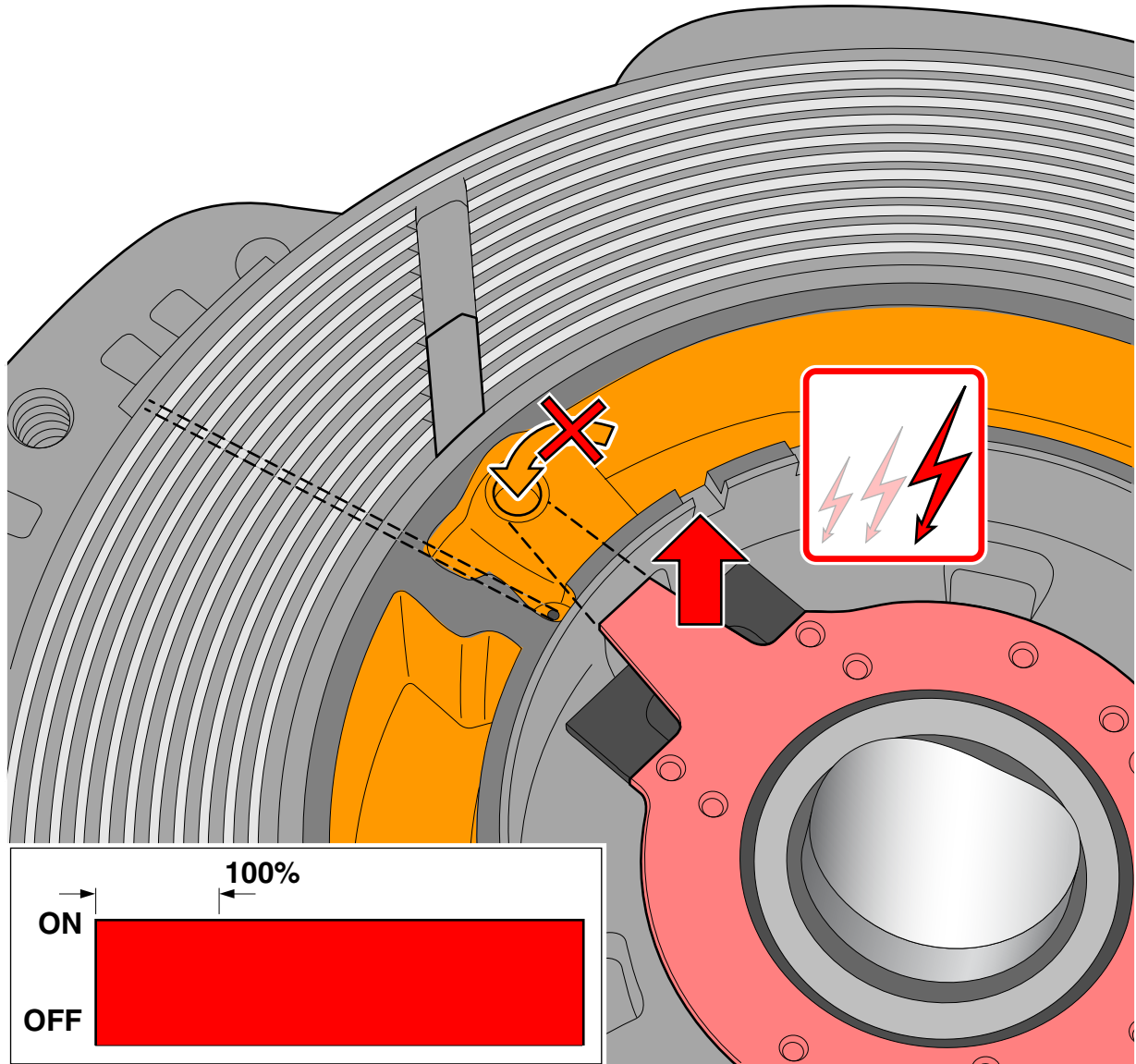

The speed control is shown in Fig. 401959 - 401963. In state 1, the opening (port) in the supply chamber is kept close by the valve and this annular chamber in the rotor remains filled with silicon fluid. The valve is normally open but in this state it closes by the attraction of the magnetic field. Despite the drive speed, no torque is transferred to the secondary side (stator). The clutch is disconnected and the fan idles at a low speed as a result of the bearing friction.

i401959

## COOLING SYSTEM

### Functions

4

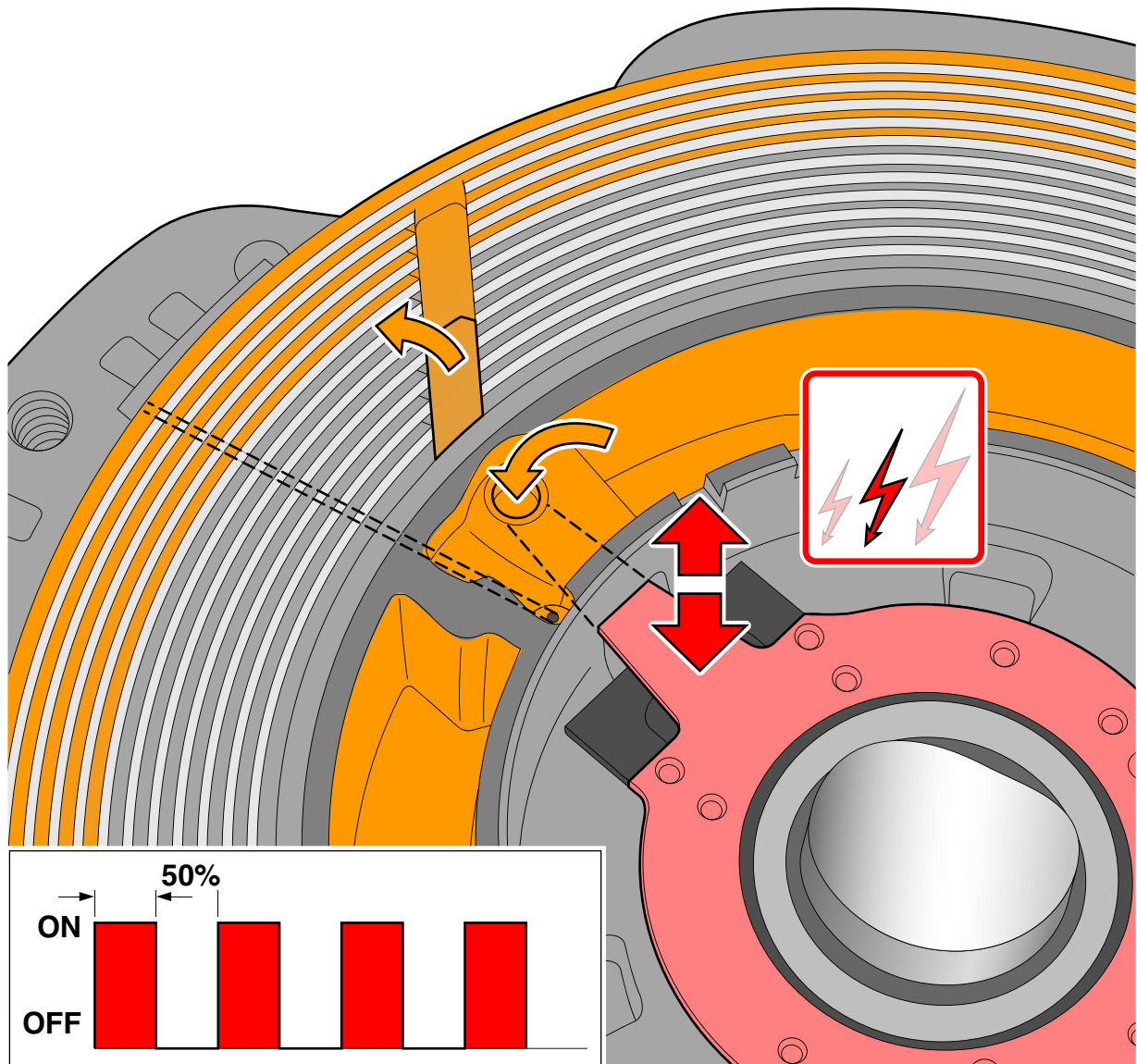

i401960

In state 2, with the port temporarily open, the centrifugal force causes the silicon fluid to move into the working area. The shear friction of the fluid in the extremely narrow, profiled working area between the rotor and stator provides the drive torque. The speed difference that always occurs between the rotor and the stator as a result of the slip is used to generate a static pressure. This pressure on the outer circumference of the rotor, pumps back the silicone fluid into the supply chamber through a return port in the disk – against the centrifugal force. Depending on how much the valve is opened, the working area can be filled to any level, providing fan speeds between idle 1 and full engagement 3.

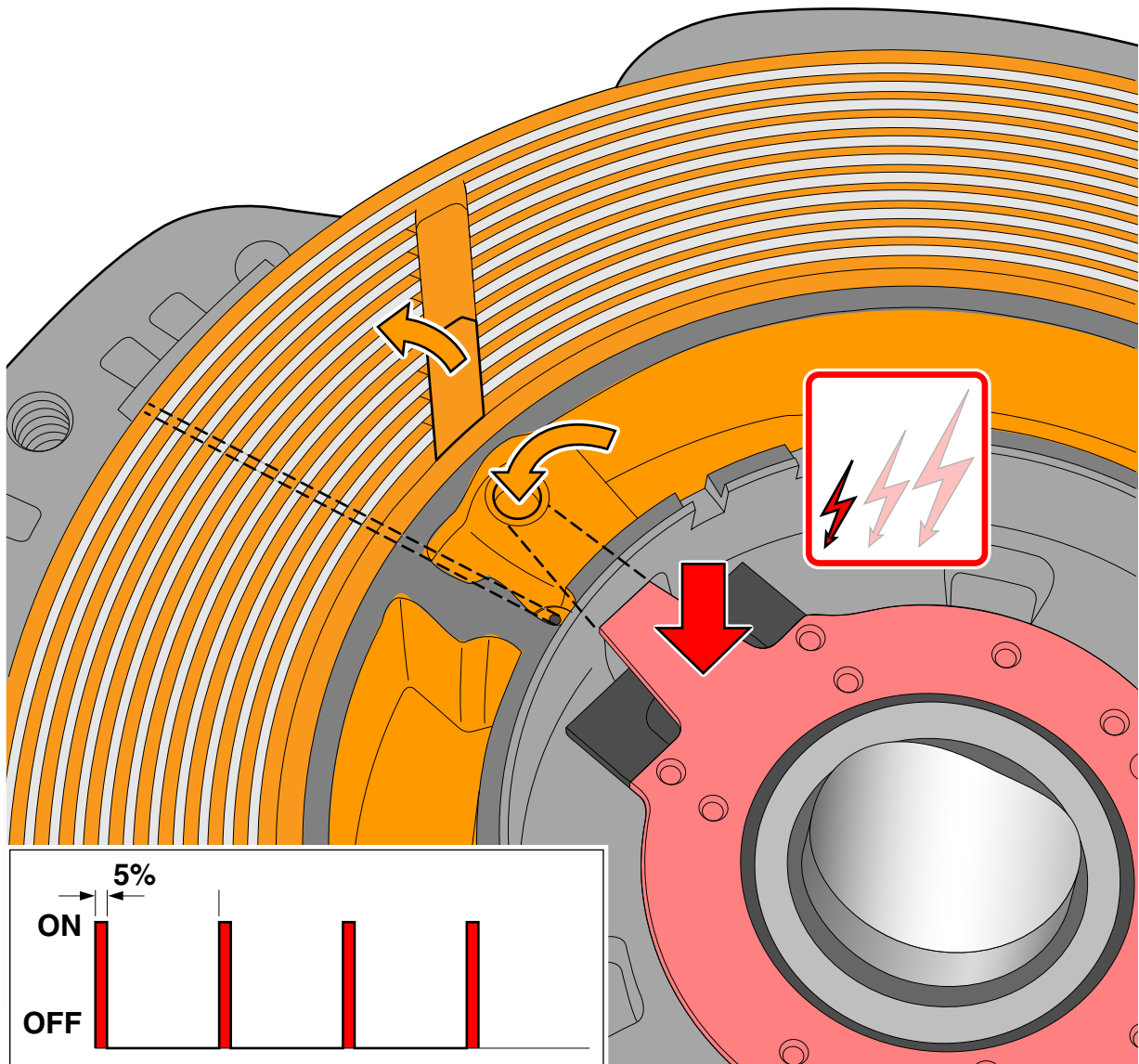

In state 1, the fan almost reaches the engine speed, apart from a small remaining slip. The degree of opening of the valve is controlled by pulsing a magnetic field generated by a coil. The valve closes when the magnetic field is "on" at it's strongest and opens when it is "off". The degree of opening depends on the PWM-on-off time proportions.

i401961

## COOLING SYSTEM

### Functions

4

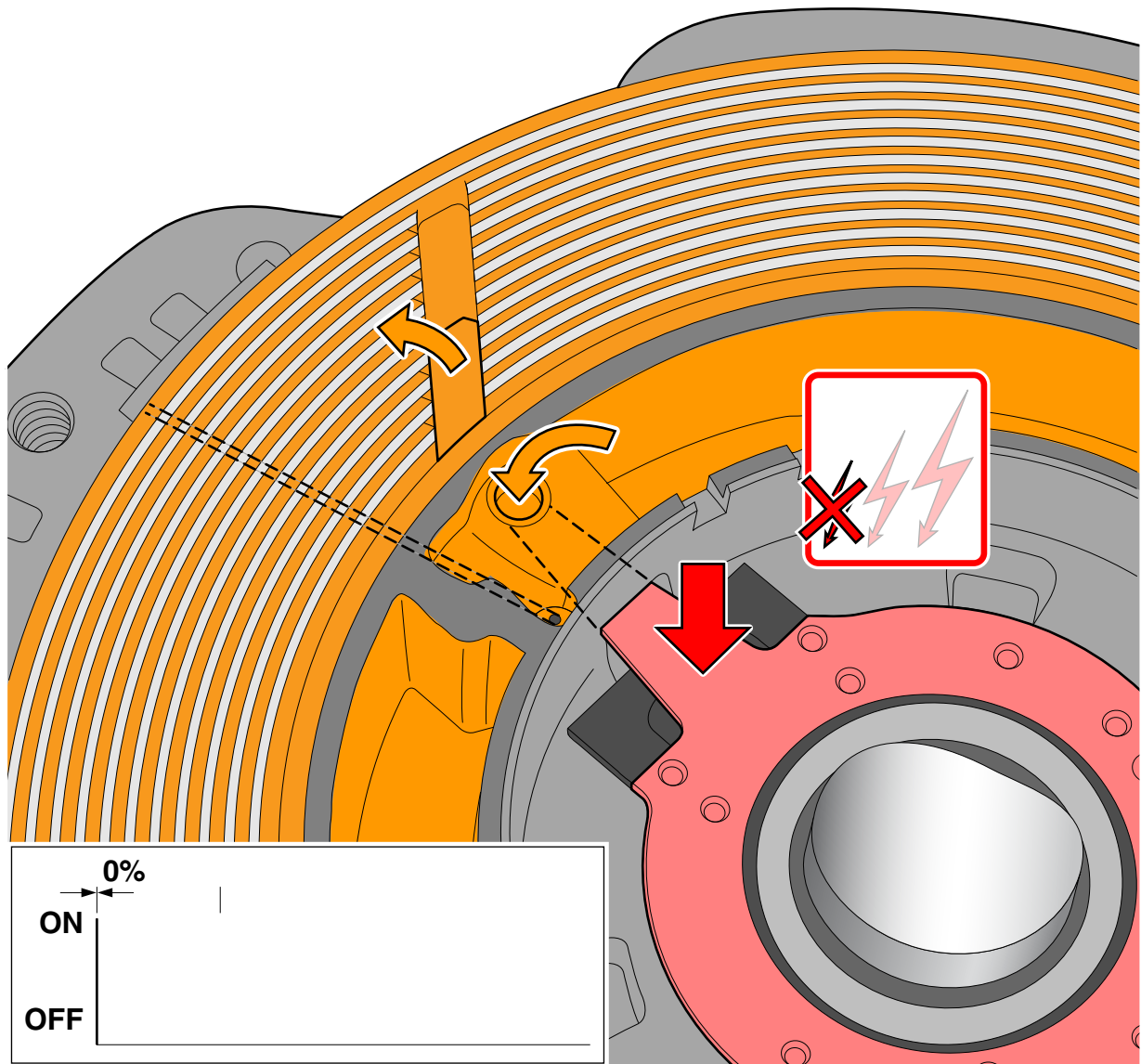

i401962

When there is no power supply to the coil, no magnetic field is generated so the valve is sprung loaded in the fully open position. As a result, more fluid is introduced than is drained off and the clutch becomes fully engaged to make sure that the fan speed, and therefore the fan speed is at it's maximum. A Hall-sensor provides feedback by continuously checking the desired fan speed against the actual fan speed. Deviation in fan speed leads to a system error warning. The fan is electrically failsafe, should the electrical supply to the coil be interrupted the fan is fully engaged and is driven at maximum speed.

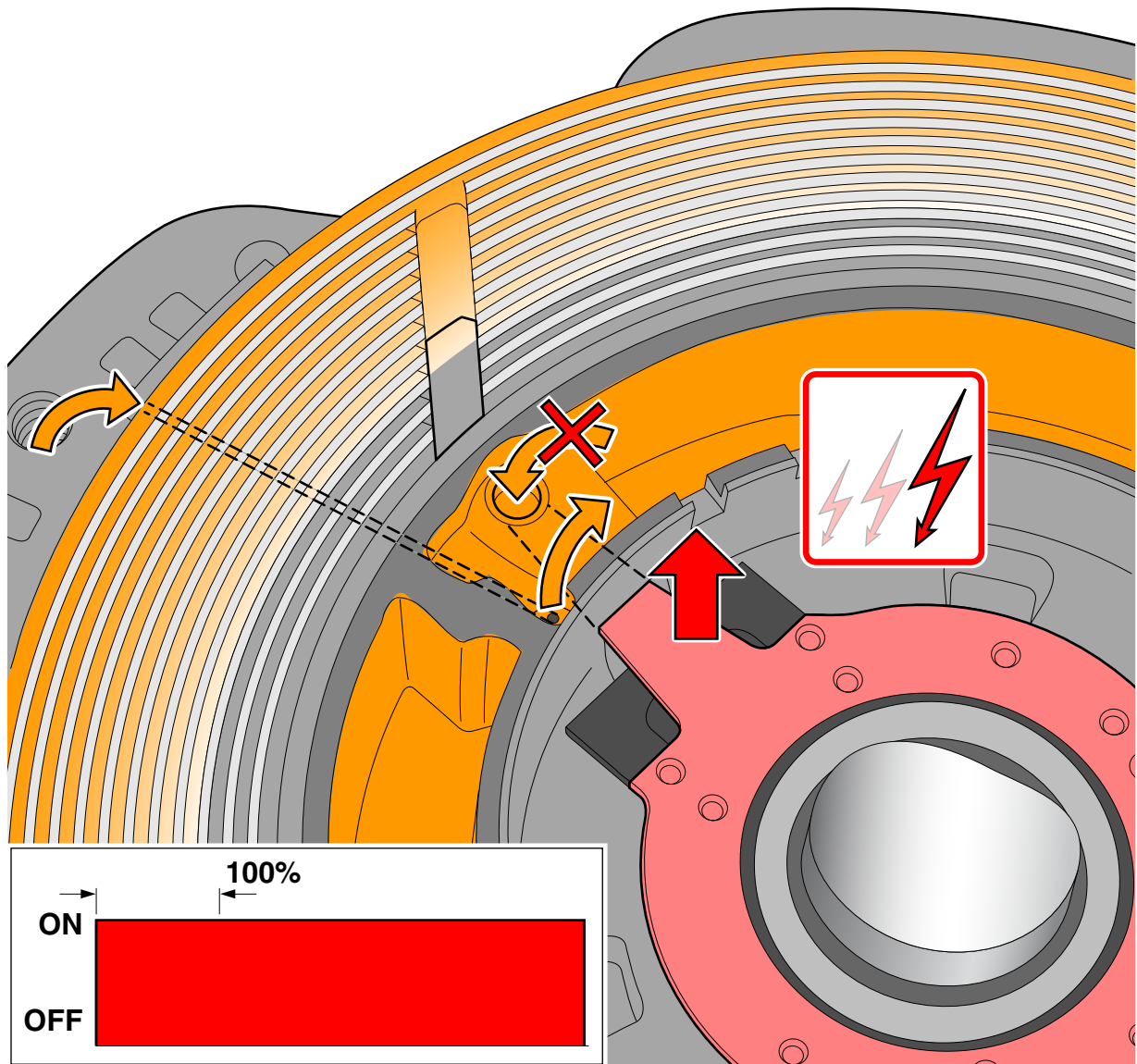

When there is maximum power (100%) supplied to the coil, a continuous magnetic field pulls the valve to the fully closed position to make sure that the fan speed is reduced to idle as quick as possible. The silicon fluid from the working area is pumped back into the supply chamber through the return bore. The speed difference between stator and rotor provides the pumping force.

i401963

# COOLING SYSTEM

---

## Functions



.....

.....

.....

.....

.....

.....

**4.2 COLD START SPEED CONTROL**

**Operation Cold Start speed control function**

- I Without Cold Start speed control function
- II With Cold Start speed control function
- A Input speed
- B Fan speed

The fan clutch is equipped with a Cold Start speed control function, designed to prevent the fan from rotating during startup of the engine. This saves fuel, noise and prevents dust blow.

The silicon fluid in the supply chamber is flowing into the working area when the coil is not energized. This is also the case when the engine is not running, so theoretically the complete content of the supply chamber could settle into the working area. When the engine is started and there is no demand for cooling the valve will be closed forcing the fluid from the working area back into the supply chamber. This can take a certain amount of time in which the fan is rotating at high speed, causing noise, dust and fuel consumption.

- 1 Partition wall
- 2 Supply opening to rotor
- 3 Return bore

The annular supply chamber is not continuous but contains a partition wall (1). This ensures that, when the engine is not running, the amount of silicon left behind in the supply chamber, can be different depending on where the engine has stopped. The amount of silicon remaining in the supply chamber does not have to be pumped out of the working area so less time is needed to reduce fanspeed. The fanclutch is assembled to the engine in the optimized position (12.00). Taking note of the position of the dowel when disassembling the fanclutch, will ensure that on re-assembly the fan is fitted back into the optimized position. Any other position gives less advantage of the Cold Start speed control function.

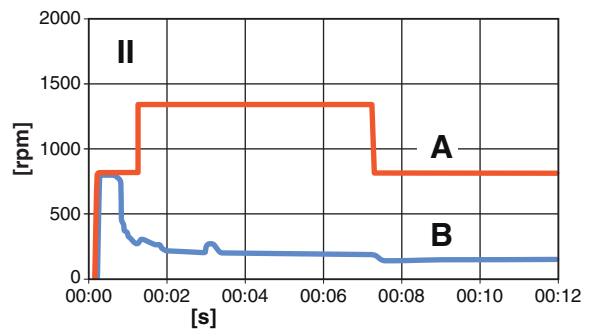
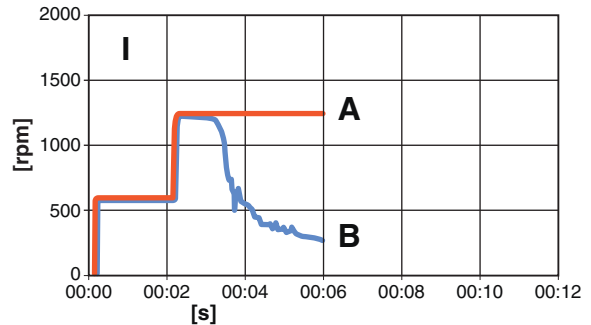

i401965

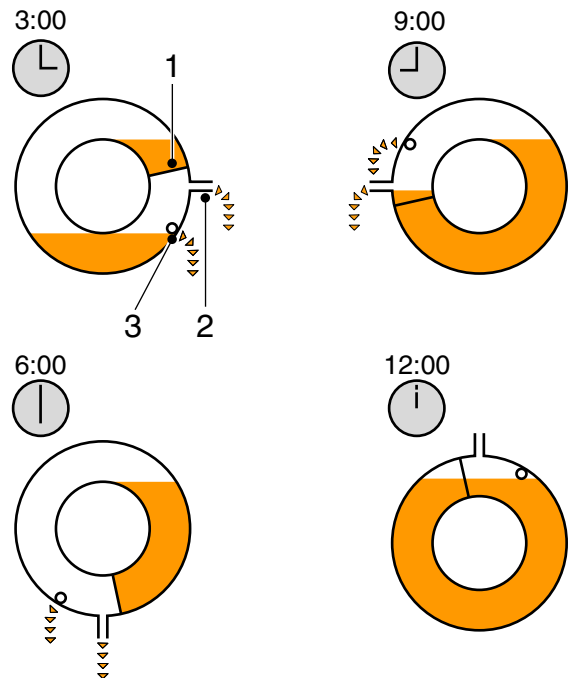

i401964

## **COOLING SYSTEM**

---

Functions

**4**



# LUBRICATION SYSTEM

## Contents

### CONTENTS

	Page	Date
<b>1. INTRODUCTION</b> .....	1-1 .....	201243
1.1 Introduction lubrication system .....	1-1 .....	201243
<b>2. SYSTEM</b> .....	2-1 .....	201243
2.1 System overview .....	2-1 .....	201243
2.2 System description lubricating oil system .....	2-2 .....	201243
<b>3. COMPONENTS</b> .....	3-1 .....	201243
3.1 Oil pump .....	3-1 .....	201243
3.2 Oil module .....	3-2 .....	201243
3.3 Oil filter .....	3-6 .....	201243
3.4 Centrifugal filter .....	3-8 .....	201243
3.5 Oil Nozzle .....	3-10 .....	201243

# LUBRICATION SYSTEM

---

## Contents

**1. INTRODUCTION**

**1.1 INTRODUCTION LUBRIFICATION SYSTEM**

The goal of the lubrication system is to prevent metal-to-metal contact between moving internal engine parts, under all possible circumstances. Engine oil is also used to transfer heat (a result of friction and combustion) from the engine parts that are not directly cooled by the coolant. The heat from the oil is transferred to the engine cooling system via the oil cooler.



*Which engine oil specifications should be used for the MX-13 engine?*



.....

.....

.....

.....

.....

.....

# LUBRICATION SYSTEM

---

## Introduction

## 2. SYSTEM

### 2.1 SYSTEM OVERVIEW

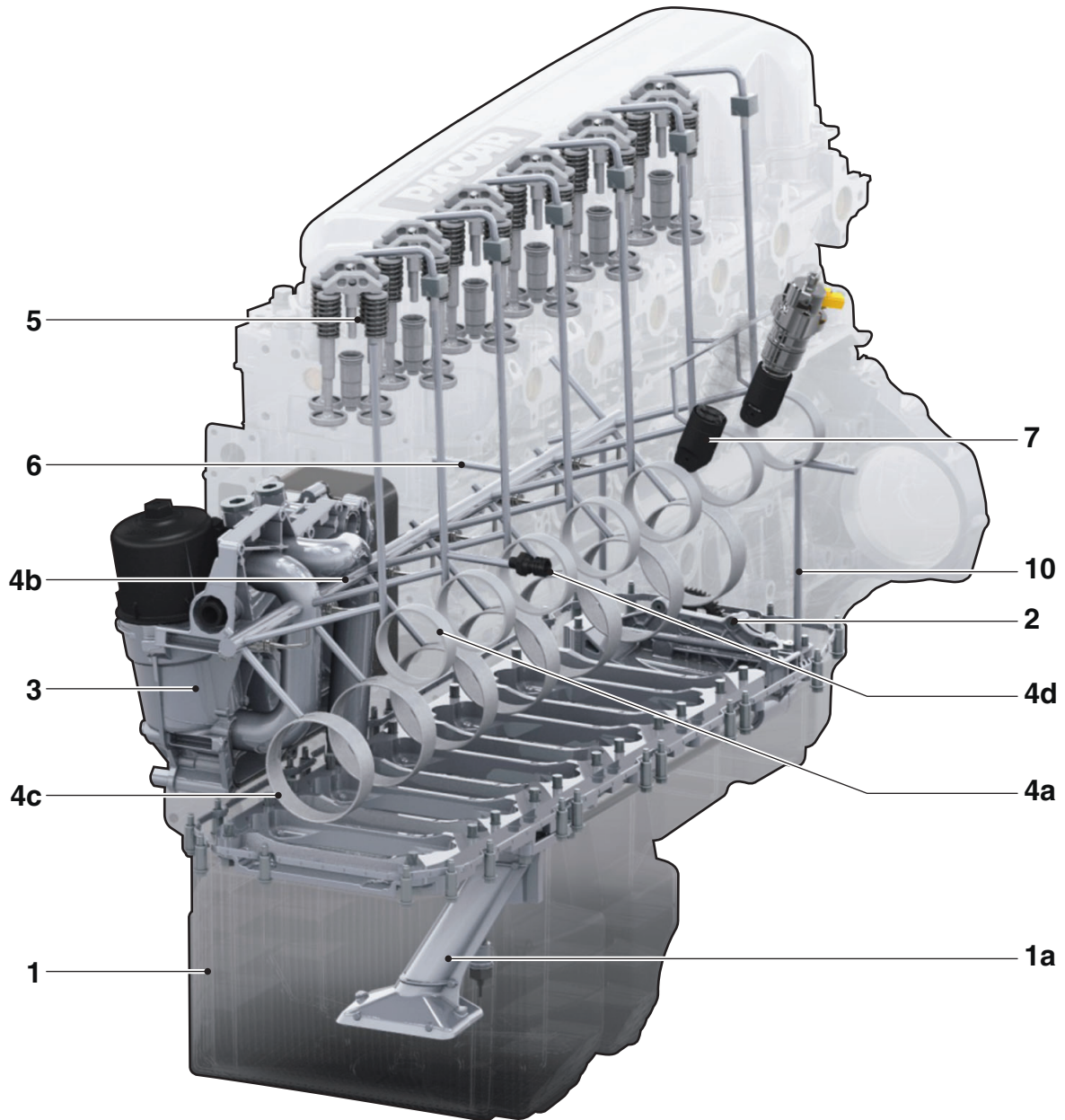

- 1 Oil sump
- 1a Oil pick-up strainer
- 2 Oil pump unit
- 3 Oilmodule
- 4a Camshaft bearings
- 4b Main oil duct
- 4c Main and Big end bearings
- 4d Oil pressure sensor
- 5 Valve train
- 6 VTG
- 7 Tappets common rail pump unit
- 10 Compressor

i402153

# LUBRICATION SYSTEM

## System

### 2.2 SYSTEM DESCRIPTION LUBRICATING OIL SYSTEM

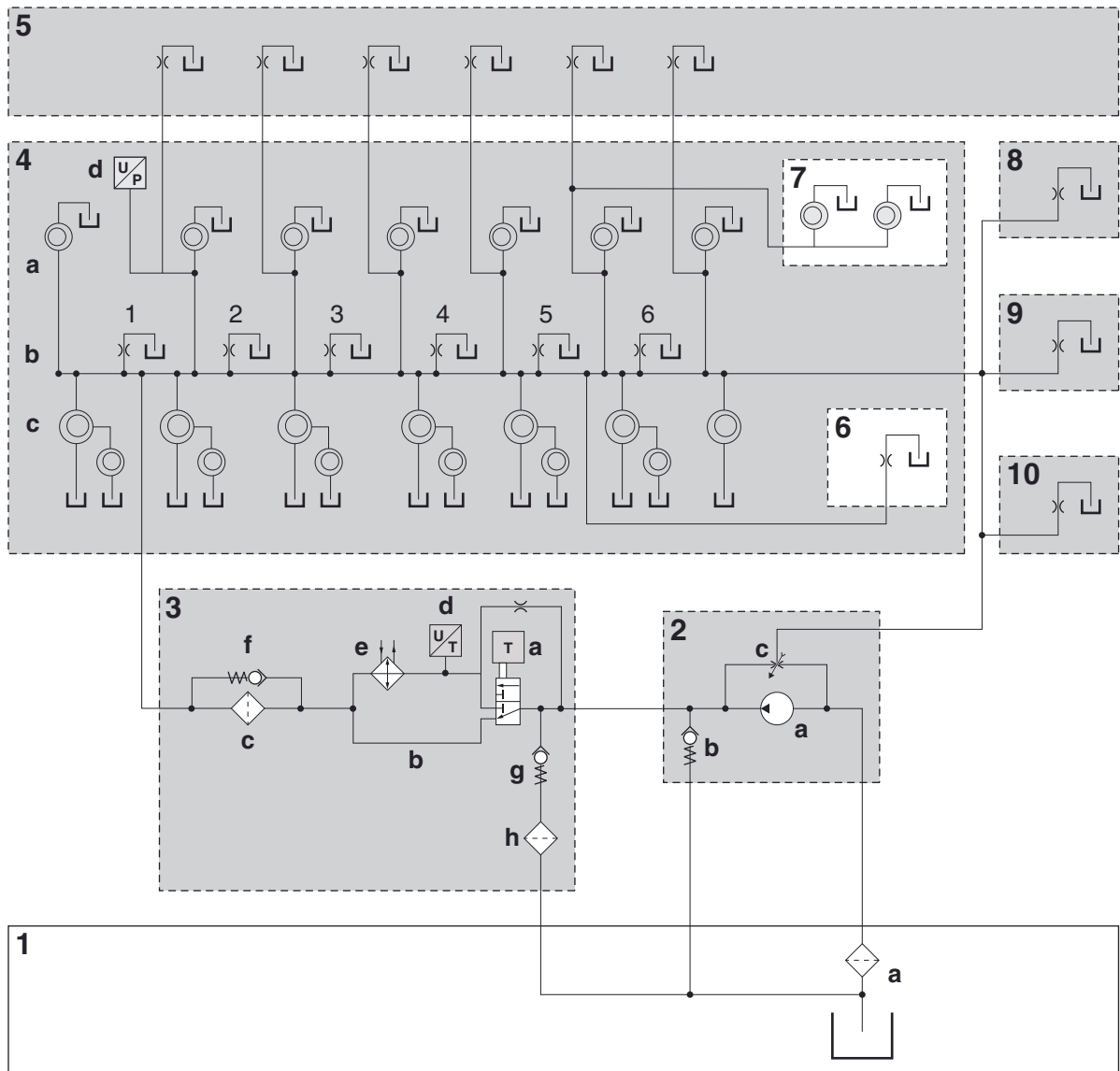

i402123

- |    |                               |         |                               |
|----|-------------------------------|---------|-------------------------------|
| 1  | Oil sump                      | 4b      | Main oil duct                 |
| 1a | Oil pick-up strainer          | 4c      | Main and Big end bearings     |
| 2  | Oil pump unit                 | 4d      | Oil pressure sensor           |
| 2a | Oil pump                      | 4.1-4.6 | Oil nozzles                   |
| 2b | Oil pressure relief valve     | 5       | Valve train                   |
| 2c | Oil pressure regulating valve | 6       | VTG                           |
| 3  | Oilmodule                     | 7       | Tappets common rail pump unit |
| 3a | Oil thermostat                | 8       | PTO                           |
| 3c | Oil filter                    | 9       | Gear train                    |
| 3d | Oil temperature sensor        | 10      | Compressor                    |
| 3e | Oil cooler                    |         |                               |
| 3f | Oil pressure relief valve     |         |                               |
| 3g | Non-return valve              |         |                               |
| 3h | Centrifugal filter            |         |                               |
| 4  | Engine block                  |         |                               |
| 4a | Camshaft bearings             |         |                               |

5

The oil pump is driven directly from the crankshaft. The oil pump (2a) draws the lubricating oil from the oil sump (1) and pumps it to the oil module (3). The lubricating oil flows past the thermostat (3a) and directly to the oil filter (3c) or goes via the oil cooler (3e). From here the lubricating oil goes to the main lubricating oil channel (4b) in the cylinder block. From the main lubricating oil channel, the lubricating oil is further distributed to the various components requiring lubrication.

A centrifugal filter (3h) may be included parallel to the lubrication system.

A pressure limiting valve (2a) is installed in the lubrication system after the pump. When the pressure set for the pressure limiting valve has been reached, the valve opens and any excess lubricating oil is discharged to the sump.

The lubricating oil is cleaned in the oil filter (3c).

From the main lubricating oil channel (4b) lubricating oil is supplied to the crankshaft main bearings (4c) and via an oil channel in the crankshaft to the big-end bearings.

Lubricating oil is led from the main lubricating oil channel to the camshaft bearings (4a).

From the camshaft bearings, a lubricating oil channel runs through the cylinder heads to the rocker seat (5).

From the main lubricating oil channel, the lubricating oil goes to the bored hub of the compressor gear (10). From the bored hub, the lubricating oil reaches the compressor gear.

From the compressor gear, the lubricating oil is supplied to the other gears.

The pistons and the upper big-end bearings are lubricated with oil nozzles (4.1-4.6) that are connected to the main lubricating oil channel (4b). In addition to its lubricating function, the lubricating oil has an important cooling function. A bore at the top of the connecting rod makes sure that the lubricating oil sprayed against the piston head by the lubricating oil nozzles can reach the upper big-end bearing.

A lubricating oil channel running from the main lubricating oil channel is connected to the lubricating oil pipes leading to the VTG (6). The lubricating oil discharge pipes from the VTG are connected to a channel in the cylinder block, from where the oil returns to the sump.

## LUBRICATION SYSTEM

---

### System

A lubricating oil channel running from the main lubricating oil channel is connected to the common rail pump units (7); the oil that flows through this channel is used to lubricate the pump unit tappets. The return oil of the tappets flows via the camshaft in the block back to the oil sump.

A PTO (8) may be included to the lubrication system. From the main lubricating oil channel, the lubricating oil goes to the bored hub of the PTO gear (8). From the bored hub, the lubricating oil reaches the PTO gear. From the PTO gear, the lubricating oil is supplied to the other gears.

The oil pressure regulating valve (2c) regulates the pressure in the oil circuit of the engine.



### 3. COMPONENTS

#### 3.1 OIL PUMP

- 1 Suction side
- 2 Drive gear
- 3 Oil pressure regulating valve
- 4 Delivery side
- 5 Oil pressure relief valve

The lubricating oil pump is a gear pump. Inside the pump there are two gears, each with eight teeth, that are responsible for the supply of the oil to the lubrication system. The pump is located at the rear of the engine and is driven by the crankshaft.

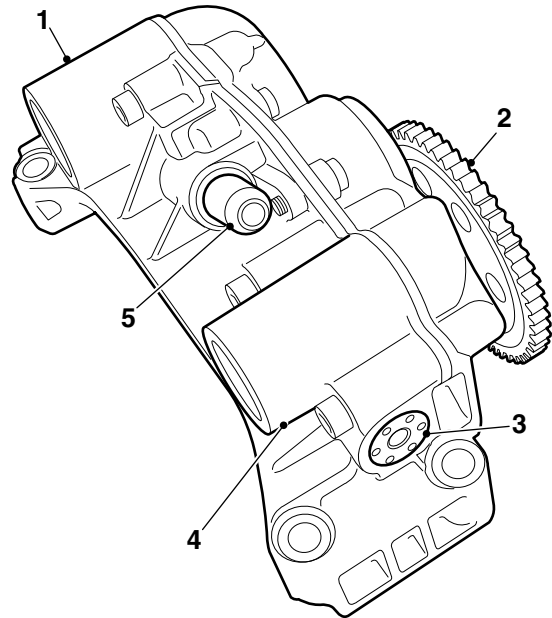

M202008

- 1 Channel through the oil pump housing from the main oil channel to the other side of the engine block
- 2 Delivery side
- 3 Drive gear
- 4 Oil pump gears (eight teeth)
- 5 Suction side

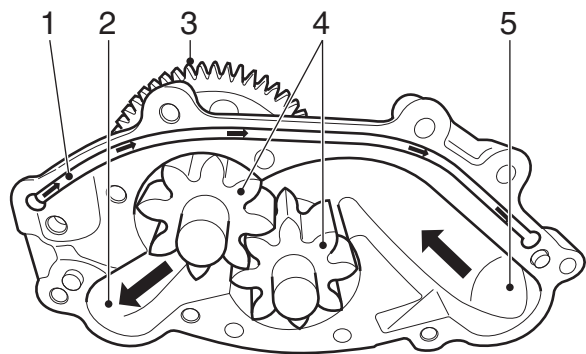

M202009

# LUBRICATION SYSTEM

## Components

### 3.2 OIL MODULE

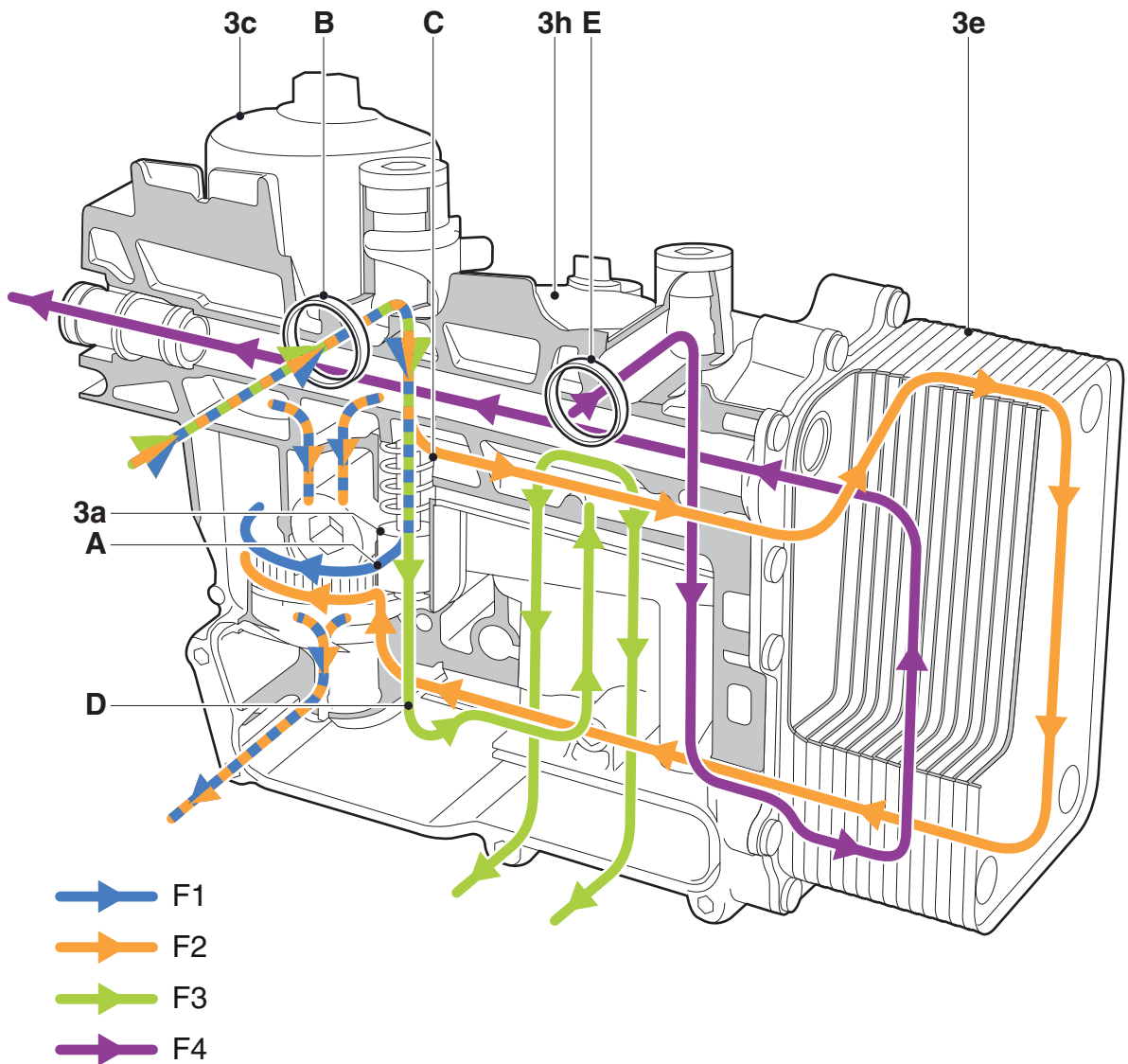

- F1 Oil flow to oil filter 'cold'
- F2 Oil flow to oil filter 'hot'
- F2 Oil flow to centrifugal oil filter
- F4 Cooling circuit

i402156-2

5

# LUBRICATION SYSTEM

## Components

- A Oil flow to oil filter
- B Oil flow from oil pump
- C Oil flow to oil cooler
- D Oil flow to centrifugal oil filter

The lubricating oil is pumped from the oil pump into the oil module via opening (B). From here the lubricating oil flows down towards the thermostat. The thermostat (3a) will arrive at a particular position due to the temperature of the lubricating oil. If the lubricating oil is colder than the wax inside the thermostat, the thermostat will shrink and the thermostat sleeve will move downwards. If the thermostat sleeve moves downwards it will open the opening (A) to the oil filter (3c) and it will close the opening (C) to the oil cooler (3e). If the lubricating oil is warmer than the wax inside the thermostat, the thermostat will expand and the thermostat sleeve will move upwards. If the thermostat sleeve moves upwards it will close the opening (A) to the oil filter (3c) and will open the opening (C) to the oil cooler (3e). As a result more and more 'hot' oil will be brought to the oil cooler (3e). The lubricating oil which is led to the oil cooler will be cooled down and brought from here via a channel in the oil module to the oil filter. The lubricating oil that flows through the oil filter will be cleaned and led to the main oil duct of the engine. The centrifugal oil filter (3h) is an option. If mounted, a small percentage of the lubricating oil flows down through the thermostat housing (D) to the centrifugal oil filter (3h). The lubricating oil that is filtered here goes directly back to the oil sump.

The coolant that cools the lubricating oil enters the oil module via opening (E). From here the coolant flows (F4) through the oil cooler and leaves the oil module via the channel to the coolant pump.

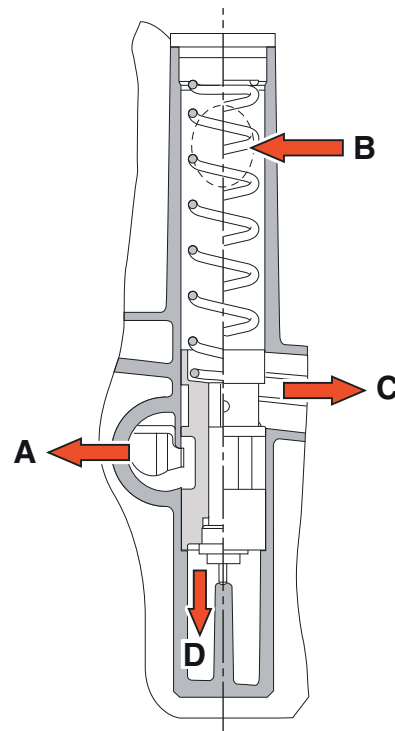

i402097-2

## LUBRICATION SYSTEM

---

### Components

The oil temperature sensor is fitted in the oil duct to the oil cooler (3e). When the thermostat closes there will be no oil flow to oil cooler (3e) and the temperature sensor. For this reason there is a small bore in the top-side of the thermostat. This bore provides under all conditions a low oil flow along the oil temperature sensor.

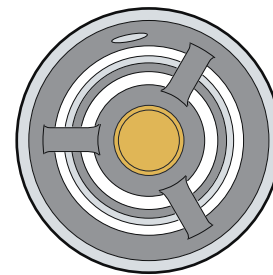
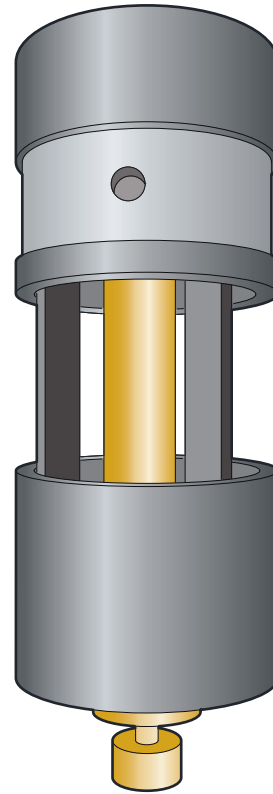

i402091-2

# LUBRICATION SYSTEM

## Components

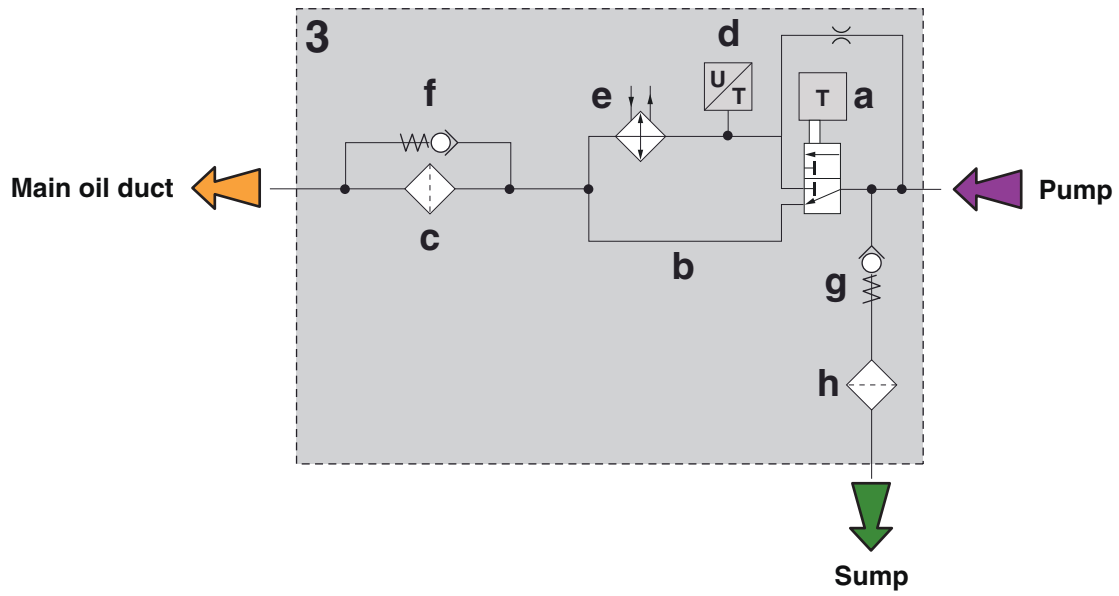

i402124

5



The drawing shows the schematic of the oil module (3). What is the function of the part 3d in the schematic?



.....

.....

.....

.....

.....

.....

.....

## LUBRICATION SYSTEM

### Components

#### 3.3 OIL FILTER

The lubricating oil is cleaned in the oil filter. A pressure relief valve (C), fitted in the filter housing (B), opens if the pressure in the oil filter becomes too high as a result of fouling or cold lubricating oil. The lubricating oil then passes through the oil filter cartridge (A) unfiltered. The lubricating oil which leaves the oil filter via opening (F) goes directly to the main oil channel of the engine.

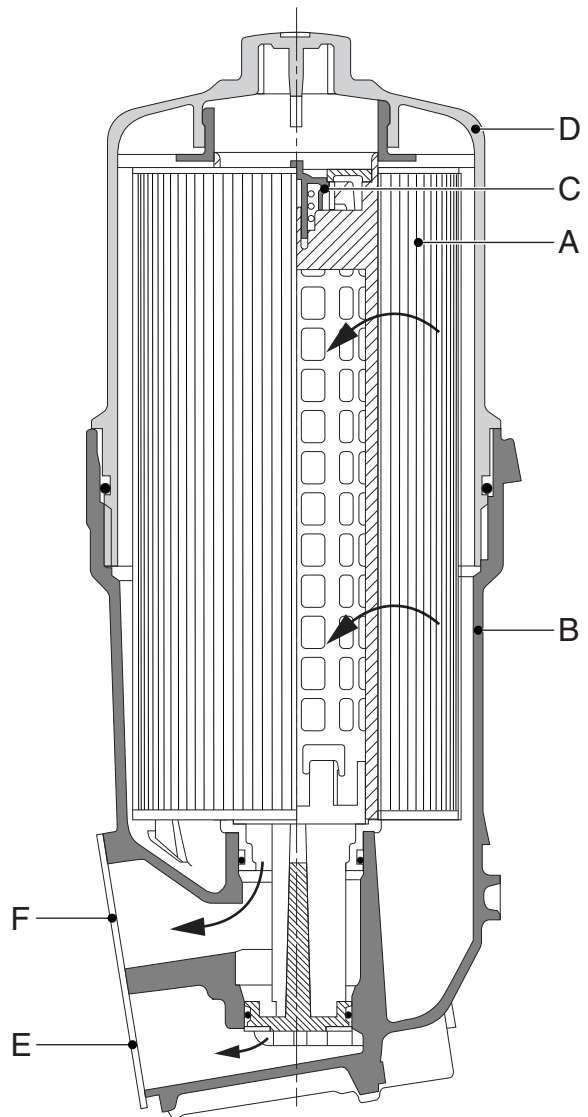

M201437

## LUBRICATION SYSTEM

### Components

If the cap (D) of the filter housing (B) is unscrewed and lifted upwards a little, this results in a connection (E) to the oil sump. Because of this the lubricating oil in the oil filter flows to the oil sump.

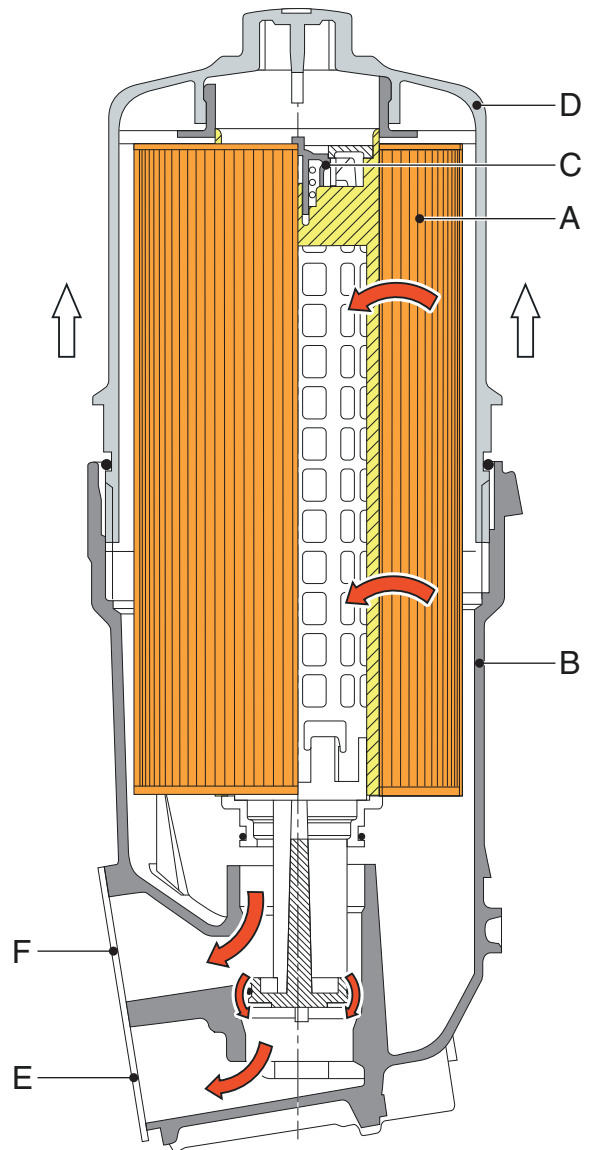

i402099

## LUBRICATION SYSTEM

### Components

#### 3.4 CENTRIFUGAL FILTER

A centrifugal filter (H) may be included parallel to the lubrication system. In this case, some of the lubricating oil will flow via the thermostat to the centrifugal filter. Under the centrifugal oil filter element there is a spherical bearing (A) which ensures that the element can turn easily when lubricating oil comes from two nozzles against the underside of the centrifugal filter housing. Centrifugal force separates the dirt particles and pollutants from the lubricating oil. The dirt particles are thrown against the wall of the element and are deposited there. The clean lubricating oil then flows back to the oil sump.

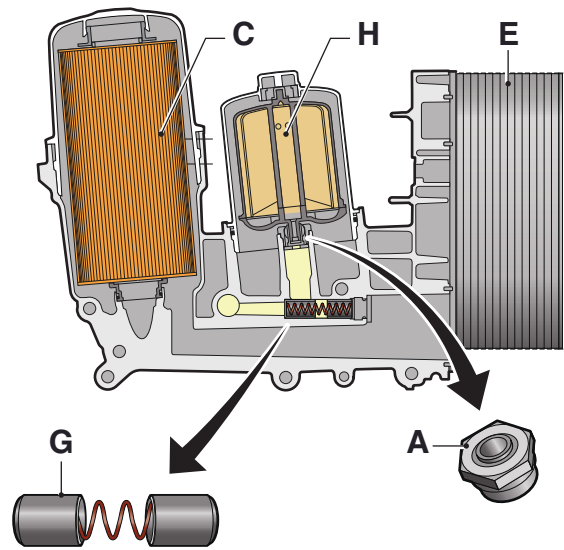

i402105-2

Under the spherical bearing (A) there is a non-return valve (G). The valve has an opening pressure of 2 bar. The valve does not open when the idle oil pressure drops below 2 bar. The centrifugal oil filter will not rotate when the valve is closed and therefore the idle oil pressure will be higher. This prevents unnecessary warning on the DIP-5. In addition, this non-return valve ensures that when the engine is turned off the main oil channel and the centrifugal oil filter cannot fully leak out. Because of this the lubrication system of the engine will be at pressure more quickly when starting up.

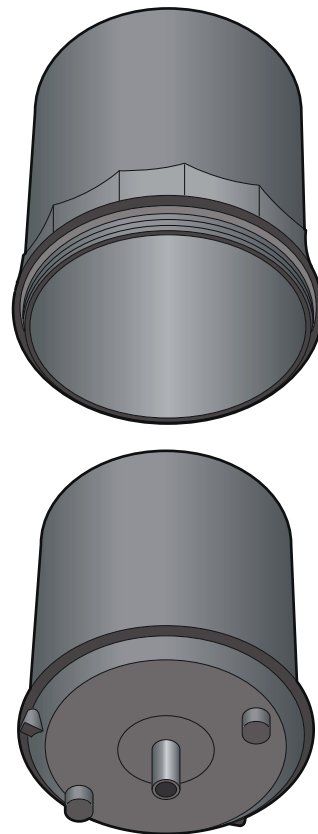

i402100-2



# LUBRICATION SYSTEM

## Components



The drawing shows the backside of the oil module. What is the purpose of opening 1 and 3?

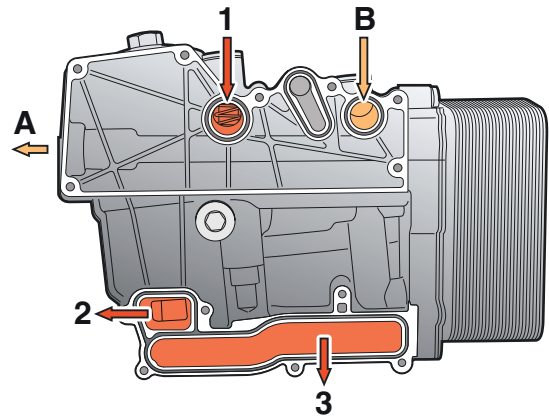

i402095-2

.....

.....

.....

.....

.....

.....

## LUBRICATION SYSTEM

### Components

#### 3.5 OIL NOZZLE

Each cylinder has an oil nozzle. The oil nozzles receive the lubricating oil from the main oil duct in the engine block. The oil nozzle continuously sprays a large amount of lubricating oil towards the steel piston head.

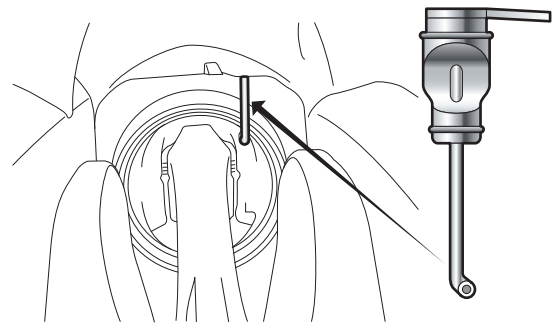

i402073-2

The piston head is fitted with a cooling channel. The oil nozzle sprays oil into the cooling channel. By means of the upward and downward movement, the oil is forced through the entire cooling channel in the piston head so that the latter is cooled. The lubricating oil splashing around and leaving the piston head lubricates the upper big-end bearing and the cylinder wall.

When working on the engine, always handle the oil nozzle with care. If the oil nozzle is bent just a couple of degrees, there is the risk that the oil nozzle is no longer directed towards the piston cooling channel. As a result, the piston head is no longer cooled optimally which can lead to serious engine damage.

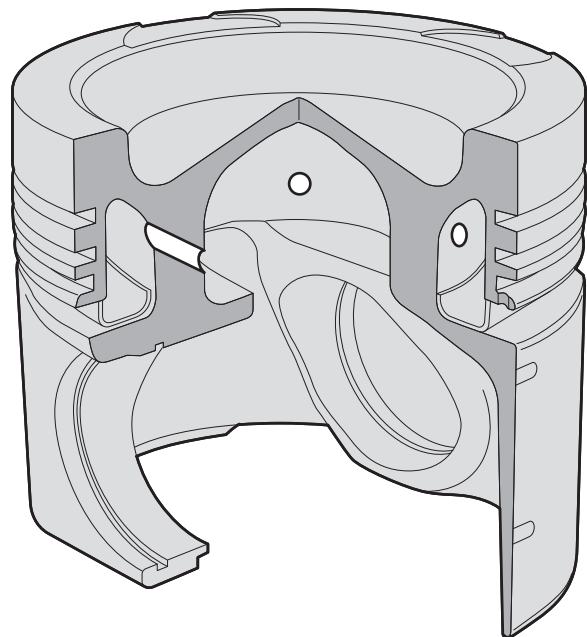

M201495-2